



Deliverable due date: M36 – November 2019

D3.4 Smart Energy Supply and Demand, Integration of RES, storage, management and Control

WP3, Task 3.3

Transition of EU cities towards a new concept of Smart Life and Economy



| Project Acronym | | mySMARTLife | |
|-------------------------------|---------|--|---|
| Project Title | | Transition of EU cities towards a new concept of Smart Life and Economy | |
| Project Duration | | 1 st December 2016 – 30 th November 2021 (60 Months) | |
| Deliverable | | D3.4 Smart Energy Supply and Demand. Integration of RES, storage, management and control | |
| Diss. Level | | PU | |
| Status | | Working | |
| | | Verified by other WPs | |
| | | Final version | |
| Due date | | 30/11/2019 | |
| Work Package | | WP3 | |
| Lead beneficiary | | ENH | |
| Contributing beneficiary(ies) | | HAM, HAM-SN, HAW, TSY | |
| Task description | | Report on the integration, performance and optimization of RES and storage energy systems in the district heating and cooling network and buildings. Definition of the management and control strategies of the systems. | |
| Date | Version | Author | Comments |
| 07.11.2019 | 0.2 | Doris Willmer (ENH) | Final Template, Chapter 1.2, Remarks to Chapter 2.2 |
| 07.11.2019 | 0.3 | Info Friese (TSYS) | Chapter 5 |
| 13.11.2019 | 0.3.2 | Simon Decher (HAW) | Chapter 3 |
| 13.11.2019 | 0.4 | Doris Willmer (ENH) | Chapter 2.1 |
| 13.11.2019 | 0.4.1 | Joachim Lange (SNH) | Chapter 6.2 |
| 14.11.2019 | 0.4.2 | Doris Willmer (ENH) | Chapter 4 |
| 14.11.2019 | 0.5 | Johannes Mielchen (HAM) | Chapter 6.1, Chapter 1 |
| 14.11.2019 | 0.5.1 | Doris Willmer (ENH) | Chapter 1,2 |
| 14.11.2019 | 0.5.2 | Johannes Mielchen (HAM) | Chapter 2.1 |
| 15.11.2019 | 1.0 | Doris Willmer (ENH) | Assembling, checking, Corrections |
| 20.11.2019 | 2.0 | Doris Willmer (ENH) | Revision after Deliverable Meeting |
| 21.11.2019 | 1.1 | Kathtarina Lange (HCU) | Official review |
| 21.11.2019 | 1.2 | Julian Sahr (HAM) | Internal review, additions Chapter 6 |



| | | | |
|------------|-----|---------------------|------------------------|
| 22.11.2019 | 2 | Doris Willmer (ENH) | Reworking after review |
| 27.11.2019 | 3 | Kaja Aniol (HAW) | Copyediting |
| 27.11.2019 | 3.1 | Joachim Lange (SNH) | additions Chapter 6.2 |
| 28.11.2019 | 4 | Doris Willmer (ENH) | Final version |
| 30.11.2019 | 5 | CAR | Final check |

Copyright notices

©2017 mySMARTLife Consortium Partners. All rights reserved. mySMARTLife is a HORIZON2020 Project supported by the European Commission under contract No.731297. For more information on the project, its partners and contributors, please see the mySMARTLife website (www.mysmartlife.eu). You are permitted to copy and distribute verbatim copies of this document, containing this copyright notice, but modifying this document is not allowed. All contents are reserved by default and may not be disclosed to third parties without the written consent of the mySMARTLife partners, except as mandated by the European Commission contract, for reviewing and dissemination purposes. All trademarks and other rights on third party products mentioned in this document are acknowledged and owned by the respective holders. The information contained in this document represents the views of mySMARTLife members as of the date they are published. The mySMARTLife consortium does not guarantee that any information contained herein is error-free, or up-to-date, nor makes warranties, express, implied, or statutory, by publishing this document.



Table of Content

| | |
|--|----|
| 1. Executive summary | 10 |
| 2. Introduction | 11 |
| 2.1 Purpose and target group | 11 |
| 2.2 Contribution of partners | 11 |
| 2.3 Relation to other activities in the project | 12 |
| 3. Integration, performance and optimization of RES in the district heating and cooling network and buildings | 14 |
| 3.1 Low-ex District Heating Island | 15 |
| 3.1.1 Task description | 15 |
| 3.1.2 The impact and the frame of the intervention in a smart city | 17 |
| 3.1.3 Prerequisites | 19 |
| 3.1.4 Previous steps and actual Status | 20 |
| 3.1.5 Conclusion | 20 |
| 4. Large scale Wind Turbines and Storage Energy Systems | 21 |
| 4.1 Action overview | 21 |
| 4.1.1 The wind farm Curslack | 21 |
| 4.1.2 Wind Farm | 21 |
| 4.1.3 Large-scale battery | 22 |
| 4.1.4 Research and Teaching | 23 |
| 4.2 Specification of the wind turbines and Battery system | 24 |
| 4.3 Measurements and Results | 27 |
| 4.3.1 Measurement of the Wind turbines from the test phase | 27 |
| 4.3.2 Measurements of the battery storage | 28 |
| 5. The roll of small-scale PV on Roofs in the Energy transition | 30 |
| 5.1 Task Description | 30 |
| 5.2 The impact and the frame of the interventions in the smart city | 30 |
| 5.3 Prerequisites | 30 |
| 5.4 Previous steps and current status | 33 |
| 5.4.1 PV-project "Kampweg" | 34 |
| 5.4.2 Further PV-projects with direct electricity power delivery | 36 |
| 5.4.3 Key Findings and the next steps | 39 |
| 5.5 Combination of PV-plant to support the climate handling with an ice-storage | 40 |
| 5.5.1 Task Deskription | 40 |
| 5.5.2 Examination of the entire period | 41 |
| 5.5.3 Investigation of maximum power consumption and maximum PV feed-in | 45 |



| | | |
|-------|--|----|
| 5.5.4 | Discussion of results | 47 |
| 6. | Current status of the management and control strategies (Action 9) | 49 |
| 6.1 | Task Description | 49 |
| 6.2 | Prerequisites | 49 |
| 6.3 | Current status | 50 |
| 6.4 | Key Findings | 53 |
| 6.5 | Next steps | 53 |
| 7. | Innovative Buildings..... | 54 |
| 7.1 | Smart home assistant living | 54 |
| 7.1.1 | Evolution of the Task | 54 |
| 7.1.2 | Stakeholders involved in this action..... | 56 |
| 7.1.3 | Advantages and the roles of the different stakeholders | 57 |
| 7.1.4 | Technical description | 58 |
| 7.1.5 | Financing of the implementation | 59 |
| 7.1.6 | Implementation plan..... | 60 |
| 7.1.7 | Main challenges during the implementation | 61 |
| 7.1.8 | Conclusions and main benefits | 62 |
| 7.2 | Smart metering | 63 |
| 7.2.1 | Implementation of modern measuring devices and in-house Visualization..... | 63 |
| 7.2.2 | Implementation of advanced measuring systems in the project area | 65 |
| 7.2.3 | Implementation of multi metering in the project zone | 66 |
| 7.2.4 | Conclusion Smart Metering..... | 67 |
| 8. | Discussion of the results (till M36)..... | 68 |
| 9. | References | 70 |
| 10. | Appendix | 72 |



Table of Figures

| | |
|--|----|
| Figure 3-1: Electricity power mix of Germany 1st half-year 2019, Source: Fraunhofer.ise | 14 |
| Figure 3-2, Energy sources for heat consumption, Source: Umweltbundesamt (Federal Environment Agency) | 15 |
| Figure 3-3: Storage in construction, source: ENH/Naturstrom | 16 |
| Figure 3-4: CO2-free supply of commercial buildings and residential buildings, source: ENH/Naturstrom | 17 |
| Figure 3-5, Project area “Schleusengraben” with the low-ex area “Schilfpark” | 18 |
| Figure 3-6, “Schilfpark”-Quarter at “Schleusengraben”, residential (blue), business (green), Fraunhofer (yellow) ... | 19 |
| Figure 4-1: left: location wind farm Curslack and the technology center energy campus; right: official corridor map with the wind turbines | 22 |
| Figure 4-2: battery storage at the wind farm curslack, source: HAW own | 22 |
| Figure 4-3, Overview of the data protocols and the connection between windfarm Curslack and TCEC | 24 |
| Figure 4-4: electricity generation of the wind farm Curslack in the test phase | 28 |
| Figure 4-5: Active Power Measurement on the battery | 29 |
| Figure 4-6: state of charge of a battery in container one | 29 |
| Figure 5-1: Suitable and unfitted roof tops – source ENH | 31 |
| Figure 5-2: Concept of electricity tenant power supply – source: ENH-own | 32 |
| Figure 5-3: Extract from the risk analysis in Deliverable 8.6, source: ENH own | 33 |
| Figure 5-4: Screenshot of the “Solar-Atlas Hamburg”, Source: https://www.geoportal-hamburg.de/Solaratlas/index.html# | 34 |
| Figure 5-5: Header of BEST No.6-Kampweg, source: ENH | 35 |
| Figure 5-6: PV-modules on the roof Kampweg 4, source: ENH | 35 |
| Figure 5-7: PV-plant Ochsenwerder just before completion, Foto Clen Solar | 36 |
| Figure 5-8: Apiculture "Ochsenwerder, source: ENH/Map Google | 37 |
| Figure 5-9: Installation plan of the PV-plant organic bakery, source: Clen solar (solar technician) | 38 |
| Figure 5-10: Organic Bakery Am Stadtrand, source: ENH/Map Google | 39 |
| Figure 5-11: Overview screen, 3D planning, source: hellosun (Solarteur) | 40 |
| Figure 5-12: GALAB power consumption (source: own) | 42 |
| Figure 5-13: Use of monocrystalline silicon solar cells (source: own) | 42 |
| Figure 5-14: Use of copper indium selenium solar cells (source: own) | 43 |
| Figure 5-15: Use of cadmium telluride solar cells (source: own) | 44 |
| Figure 5-16: Use of polycrystalline silicon solar cells (source: own) | 44 |
| Figure 5-17, Maximal GALAB Power compared to PV Power input (source: own) | 45 |
| Figure 5-18: Day of maximal GALAB Power compared to max PV Power (source: own) | 46 |
| Figure 5-19, GALAB Power compared to maximal PV Power input (source: own) | 47 |
| Figure 6-1: mySMARTLife Open Urban platform with its architecture parts and its integration | 50 |

| | |
|--|----|
| Figure 6-2: Landing page with anomaly detection status | 51 |
| Figure 6-3: Status of Electricity House Connection | 51 |
| Figure 6-4: Status of Photovoltaic system | 52 |
| Figure 6-5: Status of Combined Heat and Power Plant..... | 53 |
| Figure 7-1: Location of the Bergedorf-Bille retirement complex at Leuschnerstraße 83a-f nearby the main mySMARTLife project area in Hamburg-Bergedorf, source: FHH-Atlas. | 55 |
| Figure 7-2: Impressions of the retirement complex at Leuschnerstraße 83a-f and a sample floor plan of a 2-room apartment, source: Bergedorf-Bille | 56 |
| Figure 7-3: Scheme of stakeholders involved in the implementaton of the smart home systems, source: Borough of Bergedorf, own source..... | 57 |
| Figure 7-4: Example of a smart home set from casenio, source Casenio..... | 59 |
| Figure 7-5: Information event at a local community centre of the housing cooperation, source: Borough of Bergedorf. | 60 |
| Figure 7-6: Development and implementation scheme of the smart home action with the main contributions by the stakeholders (source: Borough of Bergedorf, own source). | 61 |
| Figure 7-7: the display of the modern measuring device, source: SNH | 64 |
| Figure 7-8: technology of the in-house Visualisation , source: SNH | 64 |
| Figure 7-9: Short-time and Long-time History, source: SNH..... | 65 |
| Figure 7-10, advanced measuring system, source: SNH..... | 66 |
| Figure 7-11: system functionality of multi metering system..... | 66 |



Table of Tables

| | |
|---|----|
| Table 2-1: Contribution of partners | 11 |
| Table 2-2: Relation to other activities in the project..... | 12 |
| Table 4-1, Technical specifications N117/2400 IEC 3a..... | 25 |
| Table 4-2, Technical specifications N117/3000 IEC 3a..... | 26 |
| Table 4-3, Technical specifications Battery System | 27 |
| Table 5-1: Specification of the PV-plant Kampweg | 35 |
| Table 5-2: Specification of the PV-plant Ochsenwerder..... | 37 |
| Table 5-3: Specification of the PV-plant Organic Bakery | 38 |
| Table 5-4: Specification of the PV-plant laboratory Schleusengraben | 41 |
| Table 10-1: Solar irradiation data Hamburg Demonstration Site of potential Analysis | 72 |



Abbreviations and Acronyms

| Acronym | Description |
|-------------|---|
| BEST | Building Energy Specification Table |
| CHP | Combined Heat and Power |
| DC | direct current power |
| ENH | EnergieNetz Hamburg eG (beneficiary from Germany) |
| GFA | Gross-floor-area |
| GDP | Gross domestic product |
| HAM | Hamburg (beneficiary from Germany) |
| HAW | Hamburg University of Applied Sciences (beneficiary from Germany) |
| kWp | Kilo Watt peak (possible power of PV-plants) |
| mySMARTLife | Transition of EU cities towards a new concept of Smart Life and Economy |
| PV | Photovoltaic |
| RES | Renewable energy sources |
| SMGw | Smart Meter Gateway |
| SNH | Stromnetz Hamburg (beneficiary from Germany) |
| TRL | technological readiness level |
| TSYS | T-Systems (beneficiary from Germany) |



1. Executive summary

The main objective of mySMARTLife project is the definition of an Innovative Urban Transformation Strategy from today's energy and mobility situation to a sustainable and intelligent city that functions well and comfortably without fossil fuels. This requires thinking different and implementing new ways to meet the challenges of modern and mobile lifestyle. The answers can be divided into the following topics:

- Energy saving and the promotion of efficient energy use
- Energy generation from renewable sources such as the sun and wind
- Replacing fossil fuels with RES electricity, hydrogen and biogas
- Intelligent control and steering strategies

The actions of mySMARTLife in Hamburg are divided into three main areas: energy, mobility and communication. This final report of Month 36 focusses on the energy part. It describes the development and the state of the demonstration of smart energy production and supply together with the integration of RES, storage, management and control in the urban city transformation.

A special challenge for Hamburg was the implementation of the low-ex district heating. The innovative combination of different energy sources for a CO₂-free heating solution of the new buildings should be in technical readiness level (TRL) 8 as "the first of its kind" in the independent real estate market. This approach has failed because the investor and building owner has opted for the cheapest form of energy supply which is currently available to him. In an alternative plan, Hamburg has managed to use a number of the innovative solutions in other combinations.

The windfarm of the HAW, connected to big power storages, is also integrated in the smart energy concept of Hamburg-Bergedorf. This includes the periphery of the urban area.

Small PV-systems on suitable roofs of the district are supporting the energy transition in Hamburg with direct power supply to the residents and users of the building. Wherever economically and physically possible, the self-consumption quota should be increased by using a battery-storage.

To support (elderly) residents and to become aware of the personnel energy consumption the part of smart energy interventions is completed by the management and control strategies as well as innovative buildings with smart home assistants and smart metering.

Deviating from the interim version (M24), the tasks "Smart Heating Islands in Retrofitting (KON)" and "Smart Heating Islands in Retrofitting (KON)" were assigned to Deliverable 3.3 with a focus on energy distribution and consumption.

2. Introduction

2.1 Purpose and target group

This deliverable provides an overview of concepts for energy production and storage as planned, developed and implemented in the project. Different aspects of a possible future energy system for the smart city are partially tested in real life during the project. The report contains a description of the planning and decision-making process as well as a technical description of the developed solutions for interested follower cities and a professional audience.

The present deliverable is structured as follows:

Chapter 2: describes possible district heating and cooling networks regarding integration, performance and optimization of RES. The innovative low-ex district heating system was not implemented in the project due to an investor's decision, but was presented due to the extensive planning in the project and the possible significance for city heating. The core element "ice storage", combined with a PV-system, is analysed in Chapter 4.6.

Chapter 3: shows the role of large RES infrastructures, such as large-scale wind turbines in combination with energy storage systems.

Chapter 4: shows the role of small-scale PV-plants on roofs and storage systems in buildings. In addition, the possible support of an innovating air condition handling with a PV-plant is stated.

Chapter 5: gives an overview of the definition of the management and control strategies for the energy production, especially RES in relation to energy consumption.

Chapter 6: shows how new innovative assistant tools, such as "smart homes" and "smart metering", could be a part of a future smart building

Chapter 7: completes this deliverable with the conclusion, a review of the main challenges and a look forward to the final implementation

2.2 Contribution of partners

The following table depicts the main contributions from participating partners in the development of this deliverable.

Table 2-1: Contribution of partners

| Participant name | short | Contributions |
|------------------|-------|---|
| ENH | | Citizen cooperative with members supporting energy transition in Hamburg and developing electricity direct delivery concepts; overall lead and development of main structure of the deliverable; writing of sections 2.1, 4, the conclusion in chapter 7, assembling the parts and first review |
| HAM | | Coordinator of mySMARTLife in Hamburg; writing of the introduction and describing living in smart homes. Chapter 1.1, 1.3, 6.1 |
| HAW | | University real laboratory for energy efficiency and RES. Operating the large-scale wind turbines; writing chapter 3 and 4.4.3 |
| SNH | | Operating the power grid Hamburg and measuring electricity power consumption; writing chapter 6.2 |
| TSY | | Developing the urban platform and defining energy control strategies; writing chapter 5 |

2.3 Relation to other activities in the project

This deliverable is allocated in task 3.3 “Smart energy supply and demand” and describes the results of subtask 3.3.1 “District heating and cooling improvements”, subtask 3.3.2 “Load management through energy-storage strategies and renewables”, subtask 3.3.3 “Cooling storage management”, 3.3.4 “Integrated renewable energy generation on building level”, subtask 3.3.5 “Integrated renewable energy generation on district level” and subtask 3.3.6 “Smart energy control in smart heating islands”. As the subtask 3.3.7 “Grid to vehicle strategies” is more of a mobility intervention, it will be reported in its own deliverable D3.7 “Mobility monitoring solutions”.

For chapter 4 (small PV-systems on rooftops), the concept of electricity tenant power supply is developed and presented in detail in WP 8 (Communication, Dissemination and Exploitation), deliverables 8.2 and 8.3 (a market analysis and business road-map).

This deliverable provides an overview of the evolution of the actions and the technical description of smart energy interventions in the project area of Hamburg-Bergedorf. Therefore, this deliverable is connected to D3.1, the baseline information of the demonstrator area and to D3.2 and D3.13, the simulation models, as well as to D3.3, the report on retrofitted actions and new buildings.

Table 2-2: Relation to other activities in the project

| Deliverable Number | Contributions |
|--------------------|--|
| D3.1 | This deliverable provides the baseline information of Hamburg demonstrator area. |

| | |
|----------------|---|
| D3.2 and D3.13 | This deliverable provides the description of the baseline report of Hamburg and the simulation models of the building stock, energy systems, transportation and urban infrastructure. |
| D3.3 | Report on retrofitted actions and implemented actions new buildings including RES and storages in Hamburg |
| D8.2 | Technology and market supervision activities / Market analysis |
| D8.3 | Report on business cases and business models / Business road-map |

3. Integration, performance and optimization of RES in the district heating and cooling network and buildings

While the energy transition in the section of electricity power production with renewable energies is already well advanced, the fossil-free and, thus, not climate damaging heat generation is still in its infancy. For this reason, particularly innovative and promising solutions have been planned for heat generation. The overall objectives of this concept are the optimization and the integration of RES in the district temperature management of business and residential building to find new ways of heating and cooling in the city development. The conceptual approach should use the partial new construction within urban conversion areas as a nucleus for the transformation primary of urban housing districts. The networking of actors at district level (between the municipalities, public and private companies, citizens and civil society) should enable the implementation of the technically innovative energy concept.

Figures 2-1 and 2-2 compare the difference in the share of renewable energies between electricity power production and heat generation.

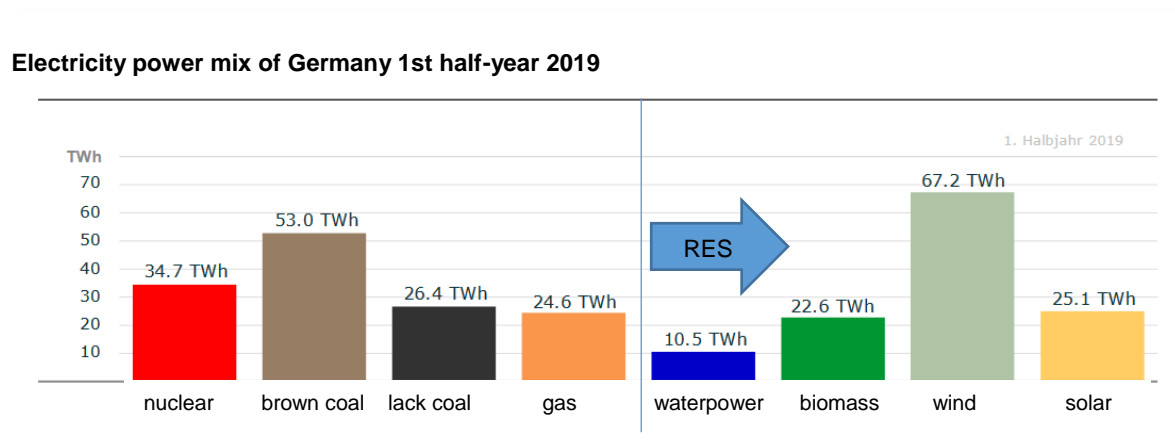

Figure 3-1: Electricity power mix of Germany 1st half-year 2019, Source: Fraunhofer.ise

Development of heat consumption with energy source in Germany

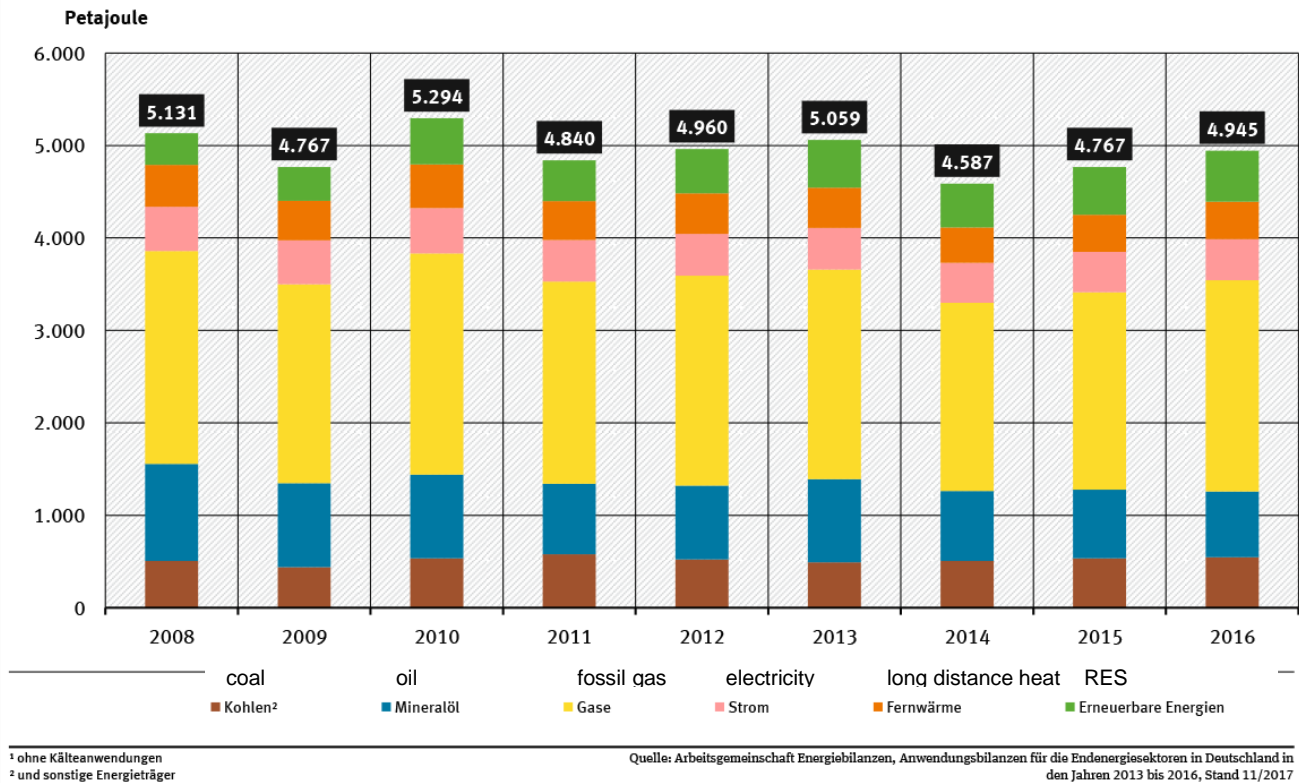

Figure 3-2, Energy sources for heat consumption, Source: Umweltbundesamt (Federal Environment Agency)

3.1 Low-ex District Heating Island

3.1.1 Task description

In Zone 1, the new construction area called the “Schleusengraben”, a high innovative concept based on the combination of diverse sources of RES should provide an autarky heat supply completely without fossil energy.

The low-ex heating network included in Zone 1 should provide heat at very low temperatures as a heat source for the heat pumps. Heat is provided by using an ice storage system in combination with heat pumps to provide additional heat in winter and cooling in summer. The underground ice storage allocates large amounts of energy reserves due to the high energy release of the water, when it changes the aggregate phase from fluid to solid and vice versa. During the heating period flow temperatures are between 30°C and 0°C and return temperatures between 10°C and -5°C. Due to the low temperatures, isolation of the heat pipes is not necessary. The return flow is preferably heated in the solar thermal plant. If the temperature in the ice storage is below 0°C, the return flow will be heated by the heat pump of the ice storage. The total storage capacity of the 3,000 m³ of ice comprises approximately 500 MWh capacity. The geothermal ambient temperature together with ambient heat from the “Schleusengraben” river and

the cooling water in summer are used to regenerate the ice storage. Cooling is supplied with a cold-water grid.

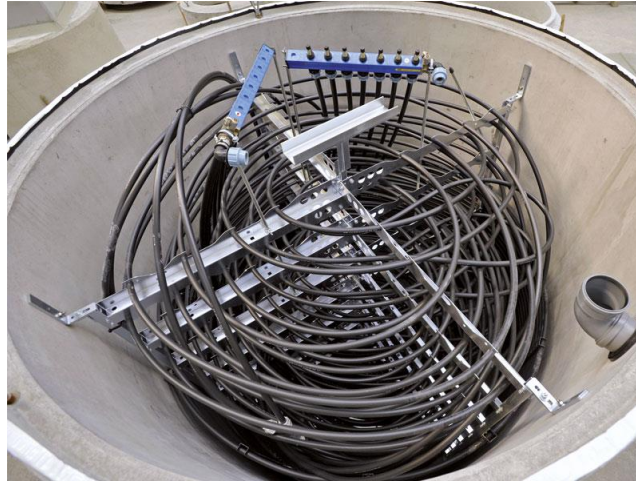

Figure 3-3: Storage in construction, source: ENH/Naturstrom

During summer, when excess solar heat is available, heat can be transferred directly to the consumer at flow temperatures around 50°C. The low-ex district heating will provide a heat source for the smartly controlled heat pumps of each single building, comprising an area of 30,000 m² of conditioned area. Heat pumps and buffer tanks are connected to the overall smart management system, which is connected to the electricity market place.

The heat pumps are preferentially running on self-consumption PV-electricity. The PV-plants would be equipped with electrical power storage in each building. This would enable a smooth load management and running the heat pumps especially at times in the evening, when heat is needed and sunshine is missing. The storage would also be connected to the intelligent energy management system. The storages would be charged and discharged according to the demands of the heat pumps and based on prediction software for demand and solar energy production forecast.

On suitable roofs, innovative hybrid PV-plants for simultaneous production of solar heat and electricity power should be mounted. They should be combined with small wind turbines on the roof tops to maximize the use of the higher wind speed caused by the building itself.

An optional buffer tank in 13 x 5 m³, total capacity 1,950 kWh, would be installed in 79 buildings of the new construction area for an adequate load balancing of the heating network. If the heating network needs additional energy, the buffer tanks will be loaded with heat powered by excess electricity from wind power plants or from the optionally installed biomass / biogas driven CHP-plant.

As a supplementary innovative solution, the industry waste heat from the Fraunhofer "IWES" test bench for wind turbines should be used and fed into the low-ex district heating grid. The following diagram shows the schematic structure of the system.

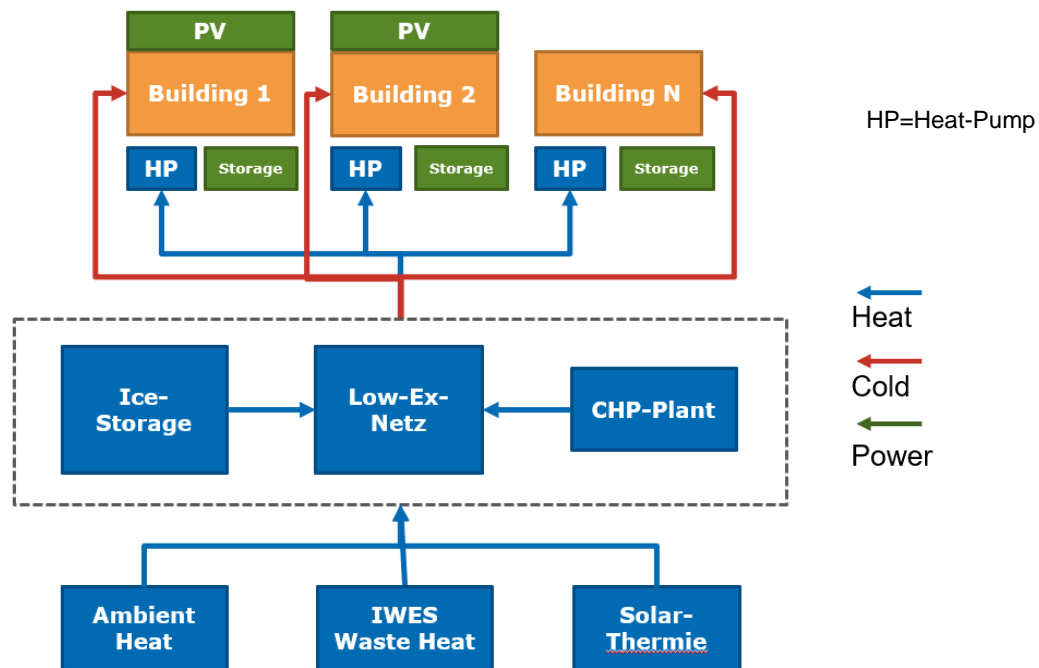

Figure 3-4: CO2-free supply of commercial buildings and residential buildings, source: ENH/Naturstrom

3.1.2 The impact and the frame of the intervention in a smart city

The “Schleusenegraben” district was planned as a real laboratory of energetically sustainable urban development, related to the elaborate testing of a transferable overall energy concept for existing and conversion districts of German cities using the example of Hamburg-Bergedorf (120,000 inhabitants).

In the context of the planning and implementation of a low-ex heating concept, the potentials and obstacles of a CO2-free energy supply at district level are examined here. The overall concept pursues a systemic approach in project structure and project procedure, which deals with technical, socio-economic, legal and institutional challenges of planning and practical implementation in an interdisciplinary and transdisciplinary manner. The results will be passed on to other municipalities and adapted to their framework conditions. The project shall answer the following general questions:

Technically: How innovative could low-ex networks be realized in the city development?

Socio-economic: What are the obstacles and how can these be overcome?

Legally: Which are the legal limits for the planning and operation of low-ex district heating networks?

Transfer: What are the barriers to transferability (in Hamburg and other municipalities) and how can these be reduced?

Integration into Hamburg urban development

The population of the Free and Hanseatic City of Hamburg will continue to grow until 2030 (Statistikamt Nord 2015). The city of Hamburg relies on sustainable, inward urban development (FHH 2014a). The city is aiming for a more efficient use of land within the existing development landscape and a promotion of the energy transition, nature and climate protection (FHH 2015, 2014a). Three goals are crucial for the Hamburg energy transition: Increasing energy efficiency, expanding and refurbishing existing energy networks, including heat supply, and expanding renewable energies (FHH 2014b). The aim of the urban planning at “Schleusengraben” district is to convert the district, shaped by trade and industry in recent centuries, into a lively urban district (Mecanoo Architects et al., 2010).

In this way, the development areas along the “Schleusengraben” river are a reference point for the climate protection concept of the Hamburg-Bergedorf district.

“Schilfpark” quarter as the nucleus of an energetically sustainable urban development

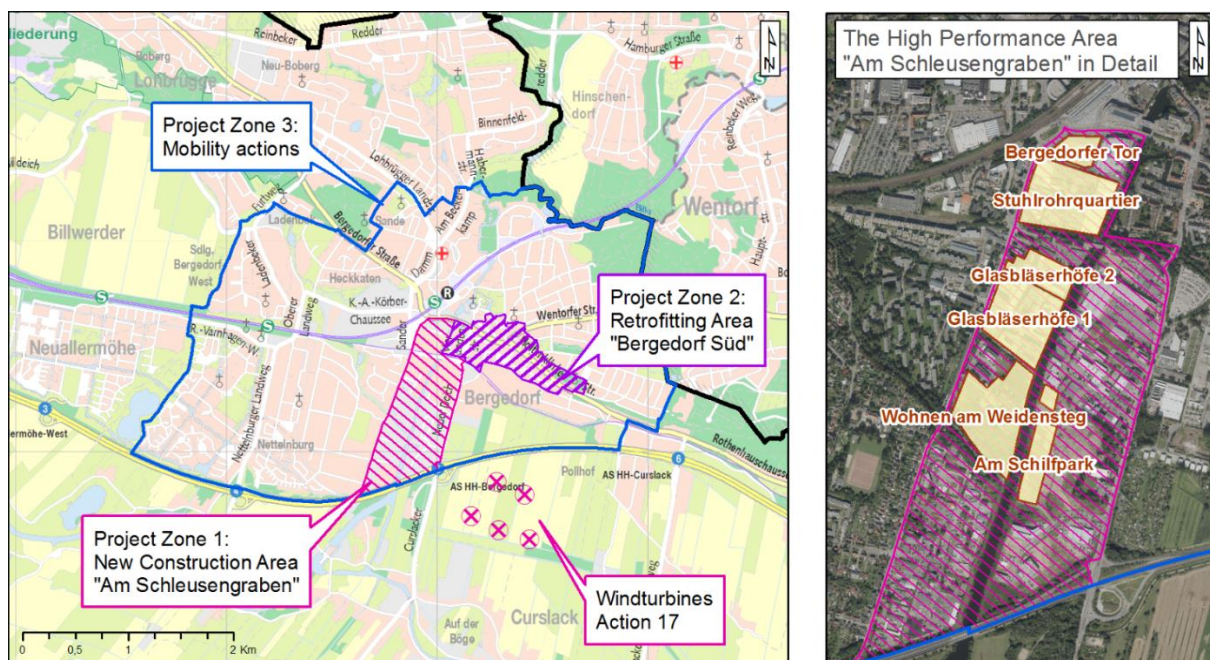

Figure 3-5, Project area “Schleusengraben” with the low-ex area “Schilfpark”

The “Schilfpark” quarter (see Figure 3-6) is situated in the southern area of the “Schleusengraben” district. Here are about 310 residential units on approximately 34,000 m² GFA and office buildings and space for crafts and research with about 30,000 m² GFA in development.

This is the Hamburg area for the energy interventions regarding the new construction buildings of the EU mySMARTLife project. The development planning is containing a cold local heating network with storage, fluctuating sources and demand side management for a network-friendly operation. As regenerative energy sources, PV hybrid and domestic waste water would be used in the “Schilfpark” quarter basically. In addition, a solar thermal system, a pressurized waste water line, surface water, a main Bergedorf waste water line and a waste heat from an industrial test block (Fraunhofer, see Figure 3-6) would be used as

heat sources. The heat pumps would be driven electrically by solar power and wind power from the roofs of the new buildings.



Figure 3-6, “Schilfpark”-Quarter at “Schleusengraben”, residential (blue), business (green), Fraunhofer (yellow)

3.1.3 Prerequisites

For implementing the low-ex three levels of prerequisites are required: technical, legal and cooperation with investors.

The **technical** requirements are given in principle. Photovoltaic is now a standard technology. Ice storage tanks have also been used successfully for years, for example at the “GALAB” laboratory (see chapter 4.6), a local life science company, in Hamburg-Bergedorf. Heat pumps are already part of the proven technology. The use of hybrid PV-plants and small wind turbines on buildings is more difficult. The special feature of the “Schilfpark” quarter is the integration and smart control of all techniques to achieve a CO₂-free heat supply. The difficulty of a hybrid PV-plant is that a PV panel produces more electricity power, the lower the temperature is. For this reason, a smart control and management must ensure a constant current of water for cooling the hybrid modules. Wind turbines of all sizes are available on the market, but the efficiency of small wind turbines is hardly foreseeable in the rough surface of a city.

Legally, the permissibility of land spanning islands with heat and electricity production and district self-consumption needs is clarified. The electricity power supply is limited to buildings in the direct neighbourhood.

Most recently, large parts of the project rely on the **cooperation** of investors who build the houses. This implies a high degree of risk for the project, if investors are unwilling to assemble an innovative but more

expensive heating technology for climate protection, but decide to implement a cheap solution. Exactly this point led to failing of the low-ex district heating in mySMARTLife.

3.1.4 Previous steps and actual Status

ENH has dealt intensively with the innovative concept of the hybrid PV and small wind turbines. Unfortunately, the whole intervention depends on the decision of the investor. ENH has been engaged in intensive negotiations with the investors of the new residential and commercial buildings to convince them of the innovative concept of combining several kinds of renewable energy. However, at least the investors decided against the low-ex temperature district heating with Bio-methane CHP as well as solar energy and preferred a cheap standard heating system based on cheap natural gas heating solutions. Such an innovative system, as planned, cannot match up with the low costs of a gas-fired heating plant and public funding.

Heat pumps were planned to be part of the low-ex district heating concept in order to regulate the heat temperature within the buildings. In addition, Hybrid PV was supposed to produce additional heat as well as the power to run the heat pumps. In sunless times the heat pumps of the low-ex heating would be provided with power by the wind turbines. The combination of locally installed wind turbines and hybrid PV to compensate the power used by the heat pumps on hot sunny days, would be the innovative and performance-enhancing way for a well-balanced and completely fossil-free heat and power plant. The combination distributes the hot water for use and thus ensures the cooling of the modules for an efficient power production.

ENH examined intensively the possibility of the use of wind energy by small wind turbines in the building area. This included a screening of the usable wind strengths, the average and the maximum wind speed. In addition, a market analysis of the producers of wind turbines and suitable small-wind turbines was carried out.

The analysis of the overall situation after the final rejection of the low-ex heating shows that the implementation of the small wind turbines is no longer meaningfully. In addition, the investor refuses to use his roofs to install RES in any form. So, this whole intervention cannot be addressed.

3.1.5 Conclusion

As described above, the implementation of such an innovative and carbon-free heating solution instead of standard is much more expensive and more complicated in maintenance. It needs an investor highly committed in climate protection to realize such purposes. The Hamburg consortium has developed an alternative plan for innovative heating islands, which, as a new and innovative technology, stores hydrogen in the natural gas network and uses it with a high level of admixture with natural gas in CHP plants. This action is described in Deliverable 3.3.

4. Large scale Wind Turbines and Storage Energy Systems

4.1 Action overview

According to the DoA, the University of Applied Sciences (HAW) Hamburg has built a wind farm close to the Technology Center Energy-Campus (TCEC) at “Schleusengraben”, located in Zone 1 (Action 17). A large-scale battery is also installed at the wind farm (Action 20). The integration of the battery is part of a larger research project in which the city of Hamburg together with the federal state of Schleswig-Holstein demonstrate key technologies for the energy turnaround. The respective project (“NEW 4.0”) is to be funded by the German federal government. The large-scale battery is used for direct power consumption from the wind turbines and for the area's ability to react to fluctuations in the wind farm's power generation. In mySMARTLife, load management and decentral storage will be implemented, in the form of a combined virtual power plant (VPP) together with the wind farm and this large battery system in order to deliver ancillary services to the power grid.

4.1.1 The wind farm Curslack

The aim is to broaden the understanding of specific issues of wind energy production, plant operation, and grid integration as well as electricity storage. The laboratories of the TCEC offer the ideal opportunity to integrate the real operation of wind turbines into applied research as well as practical training of students, e.g. through learning projects for technical and commercial management. In addition, there is an ideal platform for practice-oriented research and development. The combination of laboratory and test field (wind farm) is innovative and unique in Germany.

4.1.2 Wind Farm

In the district Bergedorf a wind farm was created. The wind farm Curslack is located one kilometer from the Technology Center Energy Campus (TCEC) of the CC4E of HAW Hamburg at the “Schleusengraben” area in project zone 1. The wind farm consists of four wind turbines with a capacity of 2.4 MW and one wind turbine with a capacity of 3 MW. Overall, the output is 12.6 MW. All wind turbines are from Nordex Modelltyp N117. The wind farm is connected to the 110/10 kV transformer station. The wind farm is projected to generate 35 GWh per year and thus cover the electricity demand of around 15,000 households in the district Bergedorf per year. The wind farm is financed by private investors with an investment of approx. 20 Mio. €.





Figure 4-1: left: location wind farm Curslack and the technology center energy campus; right: official corridor map with the wind turbines

4.1.3 Large-scale battery

The combination of wind turbines and a local battery improves the network efficiency and the marketing possibilities of fluctuating generation from renewable energies and could be demonstrated at the wind farm Curslack. The realization is a joint project of Vattenfall, Nordex Energy GmbH and the Competence Center for Renewable Energy and Energy Efficiency (CC4E) of the HAW and is part of the project “SINTEG NEW 4.0”. The battery consists of lithium-ion batteries, as they are used in electric cars and comply with the latest technology.



Figure 4-2: battery storage at the wind farm curslack, source: HAW own

Battery and wind farm feed electricity into the public grid as one system. In real operation, the power supply from the wind farm and the battery should be optimized. In the research project “NEW 4.0” innovative possibilities for ancillary services, such as the instantaneous reserve as a very fast frequency-response reserve, are being tested. In addition, the system provides control energy to compensate for

short-term fluctuations in the grid frequency. This should be avoided, as far as possible, shutdowns of wind turbines in network overload.

The main three cases during the SINTEG-project NEW 4.0 will be investigate:

Instantaneous reserve

At the first moment of a frequency deviation, the instantaneous reserve makes an important contribution to hold frequency. The instantaneous reserve is available to the conventional power plants by using inherently rotating masses. The inertia torque of the generators stabilizes the frequency without additional efforts. In the future, conventional power plants will be taken from the grid. Therefore, alternative or supplementary solutions for a sufficient amount of instantaneous reserve are needed. The use of this battery, to deliver instantaneous coverage, is to be further investigated in the project "NEW 4.0" as well as recommendations for a legal framework to show off a business model.

Primary Control power

The primary control power is intended to regulate short-term load changes. Companies, who offer this ancillary service, must secure that the maximum power is reached within a maximum of 30 seconds and is available for at least 15 minutes. The activation of the primary reserve is affected by the frequency deviation. The primary reserve provider measures the grid frequency independently at the place of production or consumption and reacts immediately to the change in grid frequency. Temporal losses, such as through communication links, are avoided and cause quick compensation. The entire control range of the primary control power is in a control band of 49.8 and 50.2 Hz. From a frequency of 49.99 or 50.01 Hz, the activation begins and the provider is obliged to counteract the frequency.

Reactive power

The reactive power is required for the operation of electrical distribution or transmission networks. It is influenced by the behaviour of users of the power grid (including reference customers, generating facilities) and the resulting reactive power behaviour of the components of the grid (e.g., lines, transformers). The investigation will show to what extent a hybrid park can deliver reactive power by using wind turbines and battery. Reactive power is currently not a market in Germany, because it will be provided by the conventional power plants. Due to the future reduction of conventional power plants and the predictable need for reactive power possible regulations should be analysed.

4.1.4 Research and Teaching

During the project period, 5 wind turbines, a battery storage and a wind measuring mast were built. For further research, 4 wind turbines were equipped with GPS Rovers and 2 wind turbines were equipped with LiDAR systems. The GPS rovers are used to determine the exact position of the gondola. The LiDAR (light detection and ranging) system measures the horizontal wind speeds. The information can be used to



gain information on wind turbulence. In addition, a supervisory control and data acquisition (SCADA) system for the wind farm was set up.

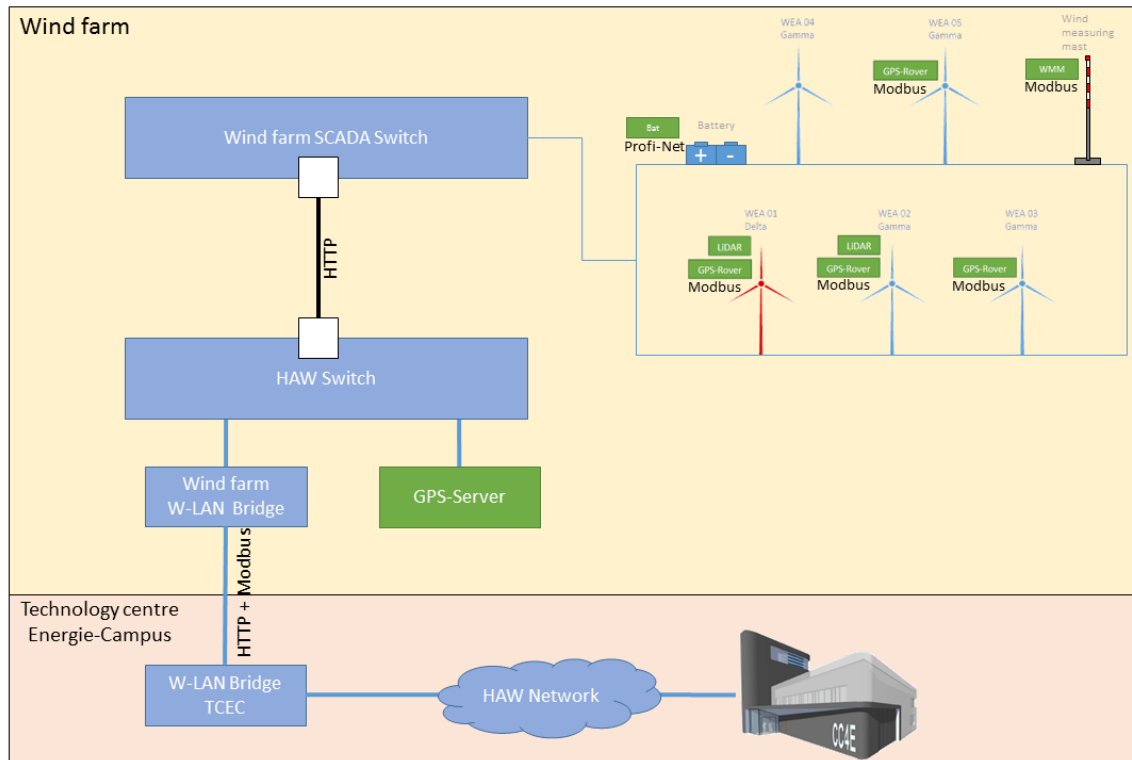

Figure 4-3, Overview of the data protocols and the connection between windfarm Curslack and TCEC

Figure 4-3 shows the data connection of the wind farm to TCEC systems. The data connection between the wind farm facilities to the SCADA system is via the communication protocol Profinet (battery storage) and Modbus TCP.

A HAW server is also realized on the wind farm. The SCADA system and the HAW server are connected over switches and communicate via HTTP. The HAW Server collected and stored the data from the GPS Rover, LiDAR, wind measuring mast, battery and the wind turbines. To get the data from the HAW server, a WLAN bridge is connected to the HAW Switch. The WLAN bridge couples two networks together and the connection will be realized by a router and a repeater. The bridge side of the TCEC is directly connected to the HAW Network.

4.2 Specification of the wind turbines and Battery system

The technology readiness level (TRL) of the task would have to be set at 9 for the wind-turbines and 8 for the battery. The following table shows the specification of the wind turbines from the wind farm Curslack.

Table 4-1, Technical specifications N117/2400 IEC 3a¹

| Operating data | |
|----------------------------------|---|
| Rated power | 2,400 kW |
| Cut-in wind speed | 3 m/s |
| Cut-out wind speed | 20 m/s |
| Rotor | |
| Diameter | 116.8 m |
| Swept area | 10,715 m ² |
| Operating range rotational speed | 11.8 rpm |
| Tip speed | 72 m/s |
| Speed control | Variable via microprocessor |
| Overspeed control | Pitch angle |
| Gearbox | |
| Type | 3-stage gearbox (planetary-planetary-spur gear) or 4-stage gearbox (planetary-planetary-differential-spur gear) |
| Generator | |
| Construction | Double fed asynchronous generator |
| Cooling system | Liquid/air cooling |
| Voltage | 660 V |
| Grid frequency | 50/60 Hz |
| Control | |
| Control centre | PLC controlled |
| Grid connection | Via IGBT converter |
| Distance control | Remote-controlled surveillance system |
| Brake system | |
| Main brake | Aerodynamic brake (Pitch) |
| Holding brake | Disk brake |
| Lightning protection | Fully compliant with EN 62305 |

¹ http://www.nordex-online.com/fileadmin/MEDIA/Gamma/Nordex_Gamma_en.pdf, p.15



| Tower | |
|--------------------------------|--|
| Construction | Tubular steel tower, hybrid tower (141 m) |
| Rotor hub height/Certification | 91 m/IEC 3a, DIBt2 120 m/IEC 3a, DIBt2 141 m/IEC 3a, DIBt2 |

Table 4-2, Technical specifications N117/3000 IEC 3a²

| Operating data | |
|----------------------------------|---|
| Rated power | 3,000 kW |
| Cut-in wind speed | 3 m/s |
| Cut-out wind speed | 25 m/s |
| Rotor | |
| Diameter | 116.8 m |
| Swept area | 10,715 m ² |
| Operating range rotational speed | 11.8 rpm |
| Tip speed | 72 m/s |
| Speed control | Variable via microprocessor |
| Overspeed control | Pitch angle |
| Gearbox | |
| Type | 3-stage gearbox (planetary-planetary-spur gear) or 4-stage gearbox (planetary-planetary-differential-spur gear) |
| Generator | |
| Construction | Double fed asynchronous generator |
| Cooling system | Liquid/air cooling |
| Voltage | 660 V |
| Grid frequency | 50/60 Hz |
| Control | |
| Control centre | PLC controlled |
| Grid connection | Via IGBT converter |

² http://www.nordex-online.com/fileadmin/MEDIA/Gamma/Nordex_Gamma_en.pdf, p.15



| | |
|--------------------------------|--|
| Distance control | Remote-controlled surveillance system |
| Brake system | |
| Main brake | Aerodynamic brake (Pitch) |
| Holding brake | Disk brake |
| Lightning protection | Fully compliant with EN 62305 |
| Tower | |
| Construction | Tubular steel tower, hybrid tower (141 m) |
| Rotor hub height/Certification | 91 m/IEC 3a, DIBt2 120 m/IEC 3a, DIBt2 141 m/IEC 3a, DIBt2 |

Table 4-3, Technical specifications Battery System

| | |
|---------------|---|
| Power | 720 kW |
| Capacity | 792 kWh |
| Type of Cells | 24 Lithium-ion modules (electric car batteries from BMW) |
| Setup | 4 x 10-feet container: 3 with 8 Storage modules each 1 container with control and measurement equipment |

4.3 Measurements and Results

4.3.1 Measurement of the Wind turbines from the test phase

Since November 2017, the work on the wind farm has been completed and gone into a one-year test run. In October 2018, the test operation was successfully completed. During the test phases, different system, regulation and communication tests were carried out. The wind farm officially celebrated its opening on October 12, 2018.

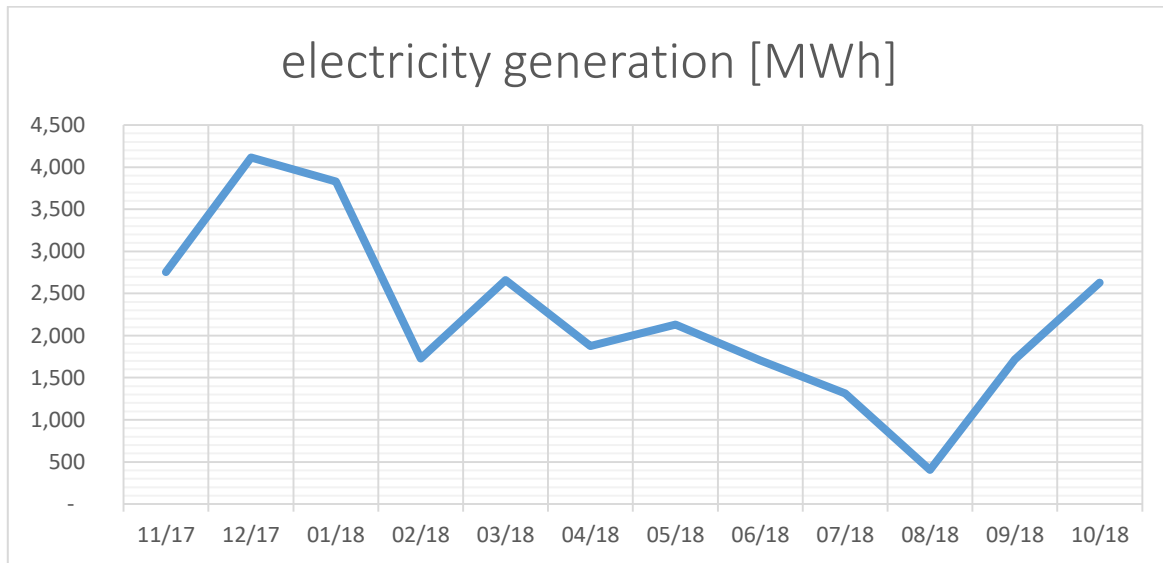

Figure 4-4: electricity generation of the wind farm Curslack in the test phase

In Figure 4-4, it is shown the electricity generation per month of the wind farm Curslack between the test run. The characteristic of electricity generation is:

- Maximum = 4,113 MWh in December 2017
- Minimum = 404 MWh in August 2018
- Mean = 2,239 MWh
- In Total = 26,862 GWh
- Full load hours = 2,132 h

The electricity demand for the district Bergedorf in the test period (11.17 - 10.18) was 333,238 GWh. Thus, the wind farm was able to cover 8.06 % (balance sheet) of the electricity demand with renewable electricity over time.

4.3.2 Measurements of the battery storage

Since the middle of January 2019, regular test with the batteries have been made. As an example, for the functioning of the connected battery the results of test phase 08.08.2019 are described. Various tests are performed to evaluate the operation of the batteries, for example their temperature behaviour. During the test different measurements were carried out. One of them is the active power of all batteries before the low-voltage main distribution, shown in Figure 4-5. Negative values mean that the active power is taken from the batteries and positive values mean that the battery takes over wind power. First the active power drops to -295 kW. At 11:30 am the process changes, because the batteries start to store power from the wind turbines. The active power reaches up to 558 kW. Less than half an hour later the active power decreases again. During the test, the batteries charge up to 558 kW four times. At the end of the test the

power drops to the lowest value of -546 kW, at this moment the batteries are discharged. The same performance underlines the state of charge (SoC) during the test. Figure 4-6 shows a battery of container one representative, because the values of the other batteries are similar. The curve starts at 57 %, which is a typical value during stand by operation. It then begins to fall by up to 16,4 %. At 11:30 am the first charging process is visible. Afterwards a fully charged battery is reached with SoC 100 %. At the end of the test SoC declines to 63 %.

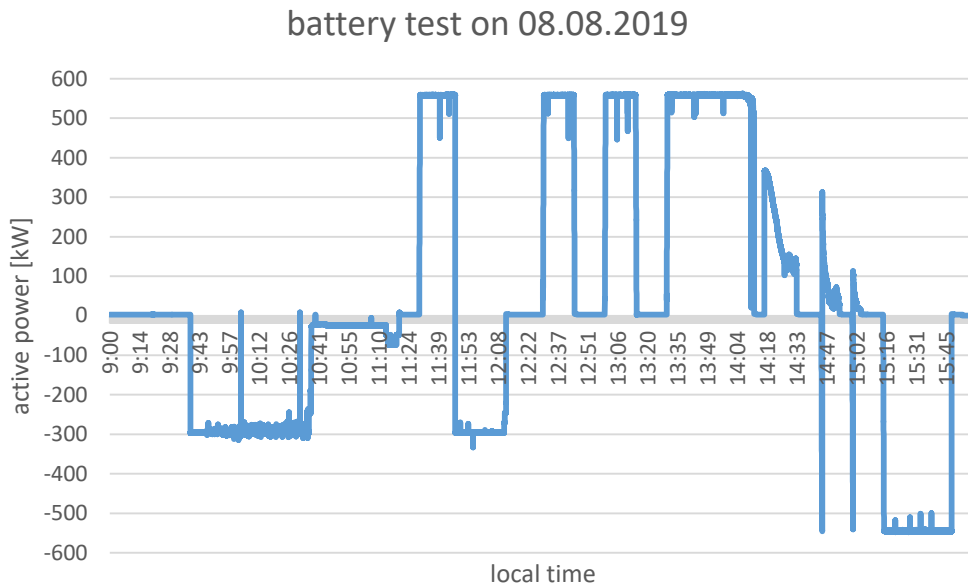

Figure 4-5: Active Power Measurement on the battery

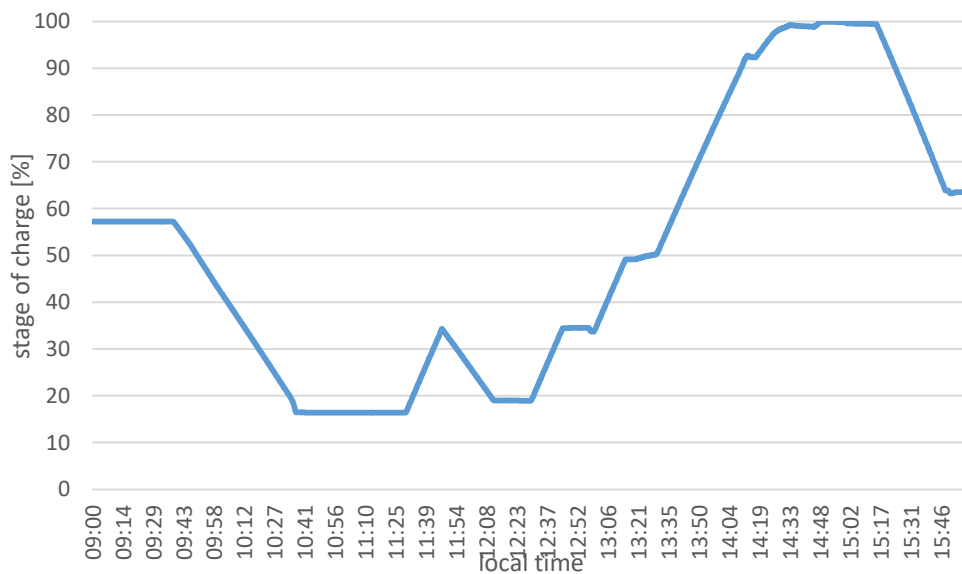

Figure 4-6: state of charge of a battery in container one

5. The roll of small-scale PV on Roofs in the Energy transition

5.1 Task Description

ENH will install about 300 kWp of PV-plants on suitable roofs in the context of mySMARTLife. To reach this, ENH is acquiring roofs in the urban district of Bergedorf and also activates the initiative "Solaroffensive" to inspire further inhabitants of Hamburg for PV-plants on their roofs. Most PV-Plants will be mounted partly in combination with tenant or direct consumption. Wherever it is economically and physically possible, they are supplemented with power storage in order to better adapt consumption with the production. ENH will promote and support sustainable development for the expansion of photovoltaics in connection with building renovation to reach the 20 % quota for PV-Power in a long term.

PV-plants will also support the energy transition by relieving the power grid when operating other energy systems, such as heat pumps. Partly addressable is the combination with heating systems with the high innovative ice-storage in the updated Action 19b and described in chapter 4.4.3.

5.2 The impact and the frame of the interventions in the smart city

These interventions aim at a decentralized power supply with renewable energies and an improved degree of autarky. The goal is to supply homeowners and tenants with green electricity from their "own" roof while relieving the electricity distribution grids at the same time. The electricity from the roofs could be used for standard consumption (light, home appliance, office equipment) or driving other energy facilities, like heat-pumps and air handling units.

5.3 Prerequisites

The essential prerequisite for the implementation of PV projects is the accessibility to suitable roofs. The roof pitch and the orientation to the sun must be suitable. Flat-roofs with tar board or tin roofs, which are not too old to guarantee convenient location for PV-plants over 20 to 25 years, would be best suited. In addition, the roofs have to be sufficiently large and not have disruptive constructions or shadings (see figure below).

If it is reasonable the PV-plants are installed in combination with a power storage system. By comparing the production curve of the solar system and the power consumption curve of the user, it is determined whether a battery storage is useful. Then the economical and physical preconditions have to be checked. The investment as a whole must be economically balanced.

The house-owners must be content to long-term contracts to provide their roofs for the PV system. This is associated with restrictions, e.g. for modifications of the roof. The financial compensation is low. If the

buildings were used for housing or work and the energy itself were consumed, the advantage would be greater.



Figure 5-1: Suitable and unfitted roof tops – source ENH

The necessary knowledge in planning and implementation of PV-plants on the roofs as well as in the contracting of tenant and direct solar projects is sophisticatedly. The entire concept involves numerous legal regulations and technical specifications that have been changed several times over the past few years by reforms.

For the “tenant electricity”, nor the roof-owners either the electricity consumers need to invest in the PV-plant themselves. Financing and construction are handled by ENH. For direct energy deliveries, two variants exist:

- i. ENH leases the roof, operates the PV-plant and sells the electricity to the roof owners for self-consumption.
- ii. ENH lets the PV-plant on a lease to the roof owner. The owner runs it and uses the electricity.

The reason for these two variants is justified by the legislation and the payable EEG-surcharge. In the first case, 100 % of the surcharge must be paid to the grid operator. In the second case, only 40 % must be paid, which increases the profitability by currently approx. 3.5-euro cents / kWh. For residential buildings with several rented apartments, a tenant electricity power concept is possible. ENH operates the PV system and offers the power supply at a price of 90 % of the basic rate of conventional providers (in accordance with the law) to the tenants of the house.

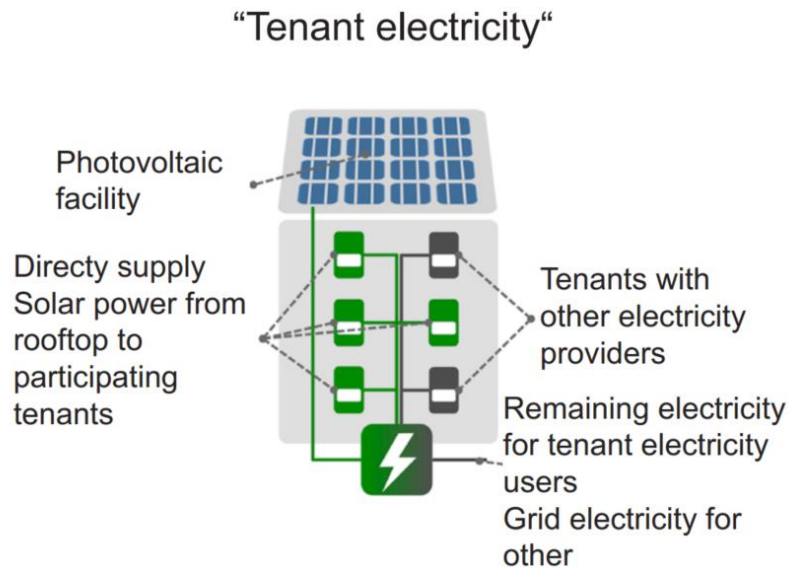

Figure 5-2: Concept of electricity tenant power supply – source: ENH-own

A huge obstacle is the unreliable legal situation. The laws for renewable energy (Erneuerbare Energien Gesetz – EEG) and tenant power supply act (Mieterstromgesetz) are changed frequently by the German government. At the last profound change of law in December 2018, the German federal government has introduced a new legislative amendment into the legislature, changed 19 energy laws and further deteriorated the conditions for PV-plants systems over 40 kWp, the so called “Energiesammelgesetz”. Especially the size that is of interest for tenants and direct current projects are thus affected by the change in the law. The amendment has come into force in April 2019.

While this report is being written (November 2019), the next legislative amendment is already for submission to the Bundestag. In the context of the “Klimaschutzgesetz” (engl. climate protection act) and the so-called “Kohleausstiegsgesetz” (engl. coal exit law) of the large coalition from CDU and SPD also regulations to the Photovoltaic and to the tenant power supply will be changed again. Under these conditions, a well-founded corporate planning is not possible.

A detailed roadmap of the business of PV with tenant power supply including a careful risk analysis is included in Deliverable 8.6. The legal uncertainty caused by the frequent changes in legislation has been identified as the most important risk factor. The market analysis of the tenant electricity business in Deliverable 8.2 shows a similar picture.

| No. | Risk title | Description | Impact | Probability | Importance | Mitigating activities | Importance after mitigating |
|----------|----------------------|--|----------|-------------|------------|----------------------------------|-----------------------------|
| ERi-ENH1 | German energy policy | Legal amendments like the fall of feed in tariffs | High | Very high | Very high | None | Very high |
| ERi-ENH2 | Component prices | Price fluctuations on the global market for solar modules and components | Moderate | High | Moderate | None | Moderate |
| ERi-ENH3 | Finance | No access to sufficient capital for investments | High | Low | High | Marketing for members | Moderate |
| ERi-ENH4 | Personnel resources | Too little personnel resources for the complex process | Moderate | Moderate | High | Cooperation with extern partners | Low |

Figure 5-3: Extract from the risk analysis in Deliverable 8.6, source: ENH own

5.4 Previous steps and current status

The PV plants should be installed on the new buildings in the “Schilfpark” area in Zone 1, in conjunction to the low-ex district heating system. Like the latter, they will be implemented as a result of the decision for standard energy supply of the investor of the buildings.

In addition, ENH has conducted an analysis of the PV-potential and is still searching for alternative buildings with applicable roofs. The objective is addressable through PV projects in Zone 2, the near urban district area of Bergedorf and other locations in Hamburg, initiated by mySMARTLife and in cooperation with the solar platform “Solaroffensive”.

The analysis for potential roofs is based on the area-wide “Solar-Atlas“ existing for the City of Hamburg, showing the solar irradiation on every roof surface. The creation of this online service was sponsored by the electric utility company “Hamburg Energie“ and implemented by Hamburg’s State Agency for Geoinformation and Surveying (LGV, linked third party of HAM in mySMARTLife). For this purpose, the amount of irradiation was simulated by an advanced simulation program which uses high resolution 3D city models as geometrical input data.

However, the database of the “Solaratlas” reflects the status from 2012. An update is desirable, not least because of the brisk construction activity in Hamburg.



Figure 5-4: Screenshot of the “Solar-Atlas Hamburg”, Source: <https://www.geoportal-hamburg.de/Solaratlas/index.html#>
 In this potential analysis, 154 roofs with approx. 9,440 kWp were identified as suitable for PV power production according to the “Solar-Atlas” (see Appendix, Table 10-1). A range of roofs were eliminated based on further suitability criteria, e.g. less than 20 kWp possible power.

The remaining roofs were roughly surveyed during an on-site inspection. The owners of the houses, which seemed suitable after all the preliminary tests, were determined, it was time-consuming due to the high data protection criteria. At least 40 house-owners were contacted for closer examination of the roof tops and, if suitable, for contracting negotiations. A large part of the remaining roofs was too old and would have to be renovated before being used for a PV-plant. Some roofs were unsuitable caused by disturbing structures (see example above). Most owners of the remaining roofs rejected the PV-plant and the electricity tenant power supply, because they would be bound by the long-term contract for 20 to 25 years. In addition, they did not find the economically feasible profit from roof lease or the possible saving on electricity costs not lucrative.

Several projects are now being implemented.

5.4.1 PV-project “Kampweg”

In Kampweg 4, the Borough of Bergedorf operates a construction yard with a material warehouse and machinery. The site includes an open-air stock with a large, suitable roof covered with trapezoidal sheets. The plan was to install a PV-system of nearly 100 kWp and direct power supply for the stock building, the adjoining administration building and the workshop. A battery storage of 10 kWh should increase the self-sufficiency quota of power consumers. For the project, the Building Energy Specification Table (BEST) No.6 was created and submitted.

Building Energy Specification Table (BEST)

(to be completed for every different type/category of proposed building)

| | | | | |
|-----------------------|---|---|-----------------------|--------------------|
| Community / site | | Kampweg 4 | BEST no. | 6 |
| total area / category | | | | 820 m ² |
| 1,1 Building Category | [1] industry & public buildings (refurbished) | | | |
| description | | industry & public buildings (refurbished) | | |
| 1,2 Local Climate | | January average outside temperature | °C | 1,3 |
| Climatic Zone | | August average outside temperature | °C | 13,7 |
| (national definition) | | Average global horizontal radiation | kWh/m ² yr | 1030,5 |
| Temperate climate | | Annual heating degree hours [3] | °Cd/yr | 3519,4 |
| gemäßigtes Klima | | | | |

Figure 5-5: Header of BEST No.6-Kampweg, source: ENH

While a roof lease agreement could be concluded with the Municipal of Bergedorf, the power supply contract failed up to now on the existing power supply frame agreement of the City of Hamburg and hurdles in the public procurement law. ENH is still working at that issue.



Figure 5-6: PV-modules on the roof Kampweg 4, source: ENH

The PV-plant on the stock-building was installed in October 2019 and has been completed for refurbishment. The monitoring takes place via a data logger of the inverter manufacturer SMA and will be transmitted to the urban platform of the City of Hamburg via router. The battery storage is still in examination.

Table 5-1: Specification of the PV-plant Kampweg

| Designation/Component | Value | Measuring unit/specification | BEV fleet (at the end of the year) |
|-----------------------|--------|---|------------------------------------|
| PV generator power | 99.83 | kWp | PV generator power |
| PV array surface | 590.60 | m ² | PV array surface |
| Number of PV modules | 363 | LX-275P/156-60+ of Luxor Solar GmbH | Number of PV modules |
| Number of inverters | 2 | 1 x Sunny Tripower CORE1 and 1 x Sunny Tripower 25000TL-30 of SMA Solar Technology AG | Number of inverters |
| Expected Annual Power | 81,570 | kWh/y | Expected Annual |

| Production (PV-Energy AC) | | | Power Production (PV-Energy AC) |
|---------------------------|---------------|--|---------------------------------|
| Finalisation | December 2019 | | Finalisation |
| Beginning monitoring | 01/01/2020 | | Beginning monitoring |
| Duration of monitoring | 23 months | | Duration of monitoring |

5.4.2 Further PV-projects with direct electricity power delivery

Some further PV-plants with direct power concept are resulting from the context of mySmartLife, in which the buildings with installed plants are implemented are in Hamburg outside the project area. However, the contacts and the interest of the homeowner have been created by mySMARTLife in connection with the “Solaroffensive” and the related reporting and events.

5.4.2.1 Apiculture Ochsenwerder

In February 2019, ENH completed a PV-plant with a capacity of just under 30 kWp on the new agricultural building of the “elbgelb” apiary in Hamburg Ochsenwerder, a few kilometres outside of Bergedorf.



Figure 5-7: PV-plant Ochsenwerder just before completion, Foto Clen Solar

The beekeeper supplies direct electricity from the solar system. In the company building, a lot of electricity is consumed for the honey harvest and other intensive work in short periods of time. In between, only a small background electricity is needed for weeks. Power consumption is therefore subject to very

distinctive fluctuations. A battery storage would not be utilized by the company-specific consumption curve.

Table 5-2: Specification of the PV-plant Ochsenwerder

| Designation/Component | Value | Measuring unit/specification |
|---|------------|---|
| PV generator power | 29,93 | kWp |
| PV array surface | 175,4 | m ² |
| Number of PV modules | 105 | Hanwha Q.PLUS BFR-G4.2 285Watt |
| Number of inverters | 1 | STP 25000TL-30 of SMA Solar Technology AG |
| Expected Annual Power Production (PV-Energy AC) | 25.751 | kWh/y |
| Finalisation | March 2019 | |
| Beginning monitoring | 01/12/2019 | |
| Duration of monitoring | 24 months | |



Figure 5-8: Apiculture "Ochsenwerder, source: ENH/Map Google

The electricity production of this PV-plant is monitored by means of a mobile router and SIM card probably via the SMA portal. The precise integration of the data into the Urban Platform will be clarified in December 2019. The power consumption can only be read manually on site. Therefore, an estimate is first made, which will be adjusted to the actual value after reading.

5.4.2.2 Organic bakery "Springer"

Within the frame of mySMARTLife, ENH has further developed the business of electricity tenant power concepts and electricity direct delivery (see Deliverables 8.3 and 8.6). At a presentation, the owner of the organic bakery got into contact with ENH. The roof of the bakery house, built in 2012, was statically already designed for the installation of a PV system. However, this was not implemented for various reasons.

After a short negotiation period, ENH has concluded a roof leasing contract and a long-term electricity supply contract with the bakery. The PV-modules and the inverters were installed completely in September 2019. The lack of space in the technical room, requires a metering cabinet built to measure. That led to a delay. The completion and grid connection will take place in December 2019.



Figure 5-9: Installation plan of the PV-plant organic bakery, source: Clen solar (solar technician)

The expected production of the plant is 93,843 kWh/y, with an expected self-consumption of 34,357 kWh/y (36.6 %). Due to the consumption characteristics, there are two cost advantages for the bakery: The working price for the direct-delivery and the demand rate for consumers over 100,000 kWh/y decrease. The self-consumption rate could be further increased with a battery storage, but the space is missing. This problem could be solved in the medium-term (2021/2022) by refurbishments related to the adjustment of the bakery vehicles to electromobility.

Table 5-3: Specification of the PV-plant Organic Bakery

| Designation/Component | Value | Measuring unit/specification |
|---|---------------|--|
| PV generator power | 99.82 | kWp |
| PV array surface | 537.7 | m ² |
| Number of PV modules | 322 | Q.PEAK-G4.1 310 Rev5 of Hanwha Q.Cells |
| Number of inverters | 3 | 3 x SUN2000-33KTL-A of Huawei Technologies |
| Expected Annual Power Production (PV-Energy AC) | 93,843 | Wh/y |
| Finalisation | December 2019 | |

| | | |
|------------------------|------------|--|
| Beginning monitoring | 01/01/2020 | |
| Duration of monitoring | 23 months | |

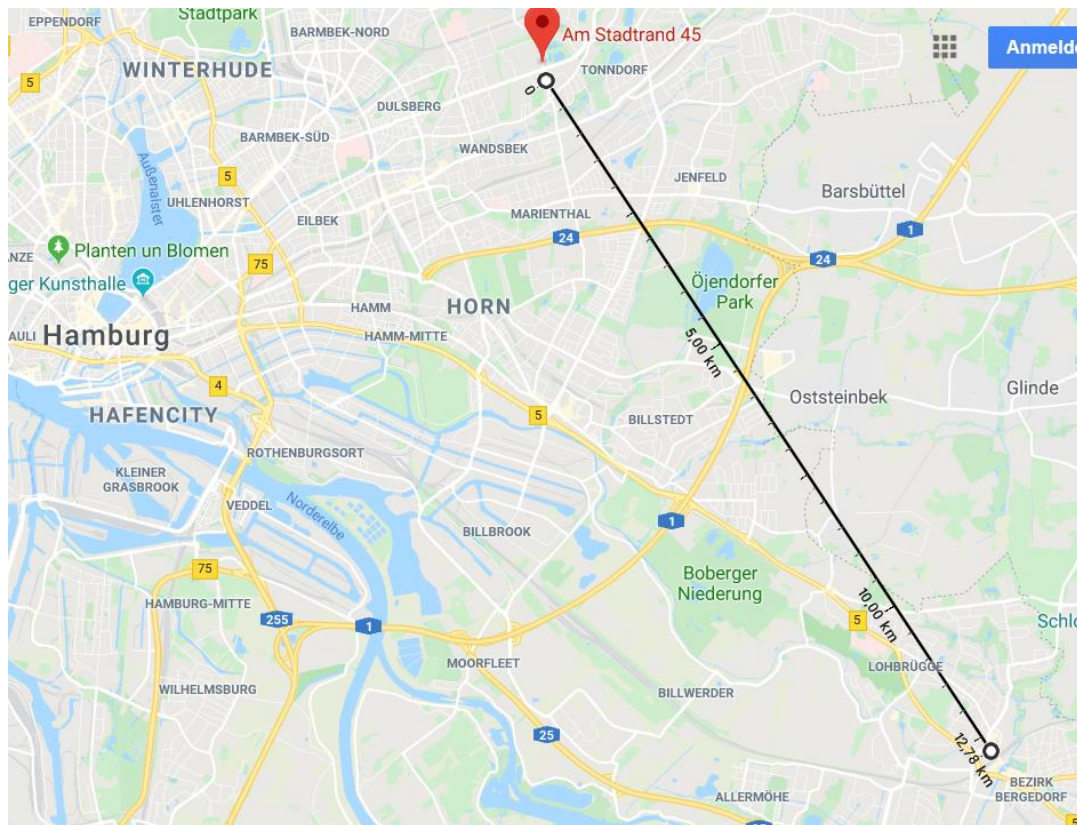

Figure 5-10: Organic Bakery Am Stadtrand, source: ENH/Map Google

Like “Ochsenwerder” the electricity production of this PV-plant is monitored by means of a mobile router and SIM card probably via the SMA portal. The precise integration of the data into the Urban Platform will be clarified in December 2019. The power consumption can only be read manually on site supplemented by the subsequent transfer of monthly load profiles.

5.4.3 Key Findings and the next steps

In the long-term, more and more house owners will combine the restoration of their old roofs to install a PV-plant. A well-thought-out public funding of energetic roof renovation would kill two birds with one stone: saving valuable heating energy through better thermal insulation of the roofs and generating roof areas for PV-plants with tenant electricity concepts or direct power supply. The quarter wide power supply referring to tenant supply for cheaper and eco-friendly power supply (according to the German tenant supply act, this is restricted to buildings in direct neighbourhood and quota of 40 % of residential buildings) will take time. The concept of a district wide usage of local PV generated power is legally impossible at the moment. The members of ENH work on events, lectures and discussions to initiate a rethinking towards more decentralized production and networking in the energy transition.

The acquisition and planning for roof areas is on-going beyond the actual implementation phase of mySMARTLife. Among others, social institutions such as kinder gardens, day centres and senior citizen homes will be addressed. These have a good consumption profile for PV electricity generation and the lower green electricity price offsets the facilities budgets and thus benefits the common good.

Also, the enhancement of the PV-plants with battery storage will be partly addressable for a higher autarky rate. Several contracts for roof mounted PV for self-consumption, partly in combination with power storage, are in negotiation.

5.5 Combination of PV-plant to support the climate handling with an ice-storage

5.5.1 Task Description

The building of a food analysis laboratory in Zone 1 is using a cooling and heating system balanced by an ice storage as its core air condition handling system. As part of mySMARTLife, a PV-plant with nearly 30 kWp will be installed on the laboratory's open stock facility and integrated into the company's electrical infrastructure. This will be done either through the straight use of direct current power (DC) or by supporting the air condition and temperature control in the building.

The prerequisite for DC use of the solar power was carefully assessed and judged as not being met. So, the approach of using the DC power of the PV-system directly, to operate the IT servers or the lighting, was rejected due to safety problems, missing technical units for non-disruptive DC operation of the servers and the conflicting production / consumption curves for the lighting.



Figure 5-11: Overview screen, 3D planning, source: hellosun (Solarteur)

Alternatively, the PV-plant will be integrated to shape the power peaks, e.g. by driving the heat pumps. For this purpose, the extensive existing energy data of ice storage, the heat pumps and the building as a whole will be analysed. The objective is to optimise the system control in terms of power consumption and to reduce power peaks. The data will be backed up for monitoring and analysing the performance of the

action. The entire electricity power produced by the PV-plant will be consumed in the laboratory building. There is no feed into the grid. If it is technically useful and economically feasible, electricity produced by the PV-plant will be buffered by a battery.

Table 5-4: Specification of the PV-plant laboratory Schleusengraben

| Designation/Component | Value | Measuring unit/specification |
|---|--------|---|
| PV generator power | 26.04 | kWp |
| PV array surface | 136.7 | m ² |
| Number of PV modules | 84 | AXIpremium AC-310M/60S of AXITEC Energy GmbH & Co. KG |
| Number of inverters | 1 | SE25K-EU-APAC/AU of SolarEdge |
| Expected Annual Power Production (PV-Energy AC) | 23,185 | Wh/y |

The main objective of the following investigation is to find out to what extent the use of a PV- system would affect the consumption of electrical energy at GALAB and whether this would result in a practical load reduction. The simulation, which was created for the design of the PV-system on the roof of the outdoor storage hall, detects that the planned collector area will be 136.7 m² large. This simulated collector area gives the basis for the following evaluation. Thankfully GALAB Laboratories also provided the load profile, in other words the course of the power consumed by GALAB for the period to be investigated from 13.09.2018 to 05.11.2019.

These data can be compared with measurements carried out by the Energy Campus in recent years. On the roof of the Energy Campus are various solar cells of the type's monocrystalline silicon, copper indium selenium, cadmium telluride and polycrystalline silicon. In addition to other data, the specific output, the output generated per square meter of collector surface, has also been recorded of these solar cells in recent years. GALAB has almost the same location as the Energy Campus, so it is possible to relate the recorded measured values to the intended, simulated PV area and therefore carry out an evaluation with real data. For this purpose, the power, which would have been generated by the different solar systems in the period, is calculated. Afterwards, this generated power is subtracted from the power consumed by GALAB Laboratories. This makes it possible to determine, how the use of different solar cells would have affected GALAB's consumption and how the economic benefit would work out.

5.5.2 Examination of the entire period

At the beginning of the investigation, a look at the load curve of GALAB should be taken.

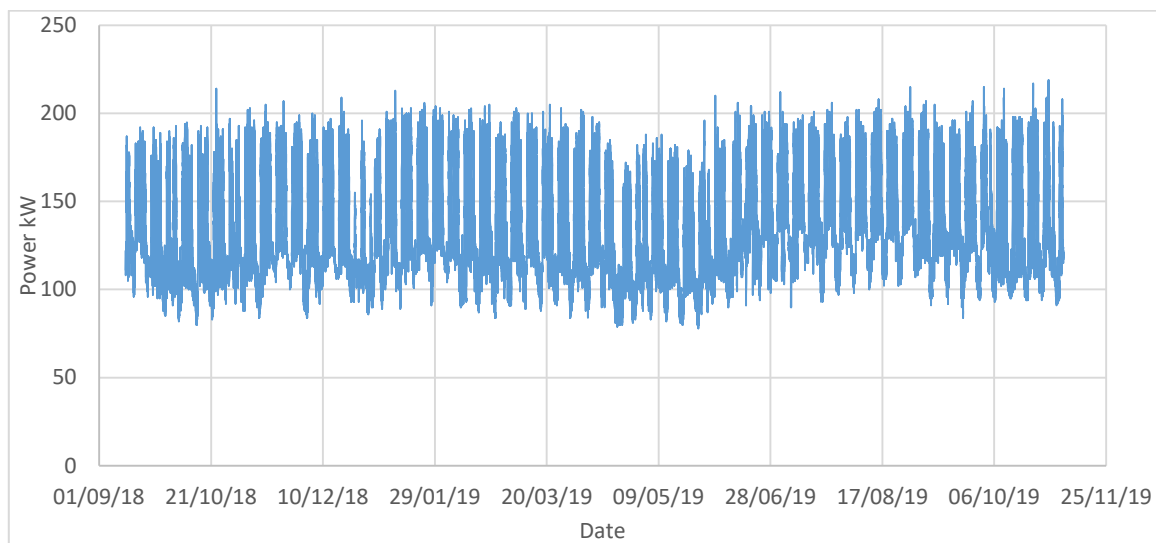

Figure 5-12: GALAB power consumption (source: own)

It can be seen that the power drawn from the grid fluctuates, but permanently is between approximately 80 kW and 210 kW in the time under consideration. Occasionally, peak loads occur which reach a maximum value of 219 kW. In addition, it can be seen that the load reference is a daily course. For example, the average power consumed during the evening and night times drops to approx. 105 kW. Whereas the consumption during the daytime, when GALAB is in operation, increases on average to approx. 190 kW.

In order to investigate how the various solar cells would have behaved in the period and what load reduction could have been achieved by them, the individual solar types are examined independently of each other in the following.

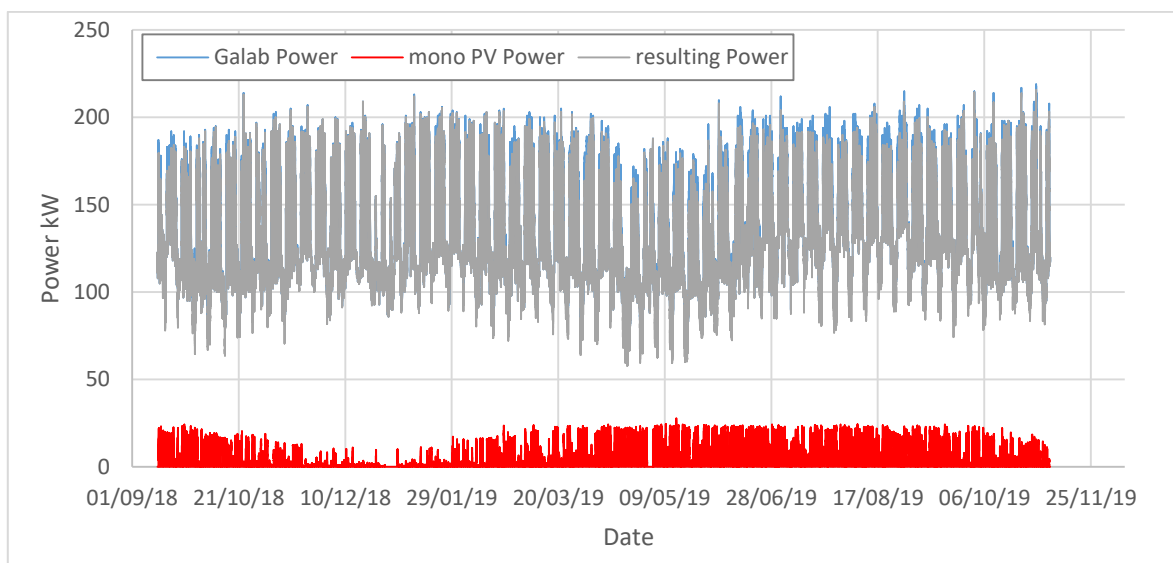

Figure 5-13: Use of monocrystalline silicon solar cells (source: own)

Figure 5-13 shows in red the course of the generated power, if the 136.7 m² of the intended collector surface had been equipped with monocrystalline silicon (mono PV) solar cells. It can be seen that a maximum output of approximately 27.86 kW could have been achieved apart from the winter months.

The course of the reduced power consumption is shown in grey. This is the power that would still have to be obtained from GALAB from the grid after subtracting the power generated by the PV-system. The blue graph shows the load curve described in the last paragraph, reduced without power input, which is the power actually consumed by GALAB.

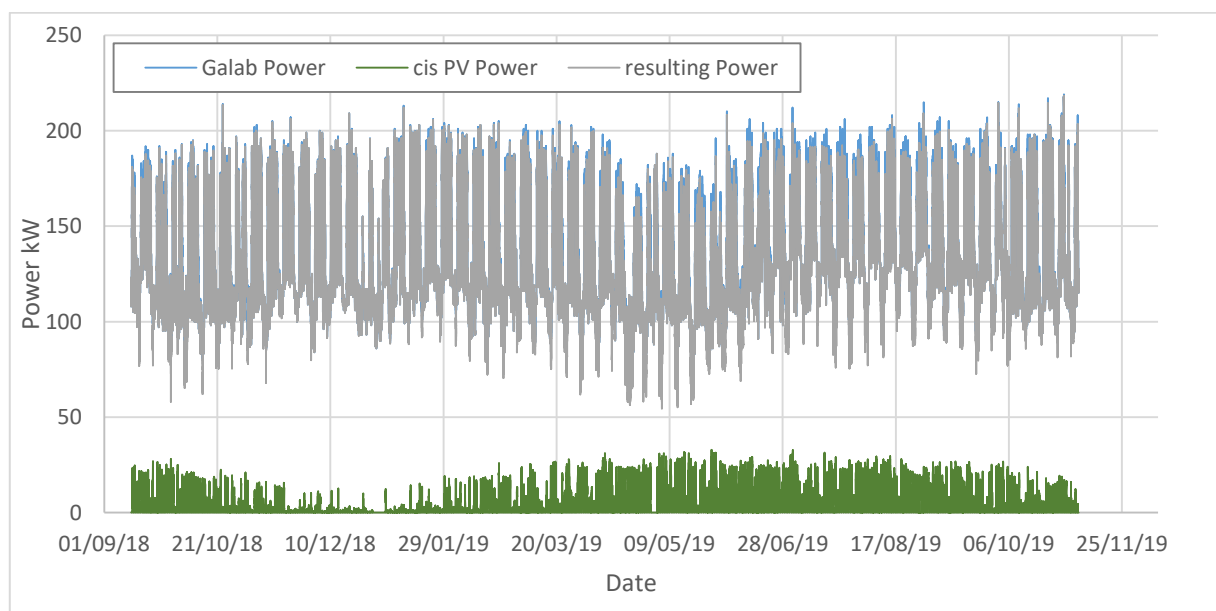

Figure 5-14: Use of copper indium selenium solar cells (source: own)

Figure 5-14 shows the load curves if solar cells of the type copper indium selenium (cis PV) had been used. Shown in green, is the course of the power supplied by the cis solar cells. These cells would have temporarily fed a maximum output of 32.93 kW into the grid during the investigated period. Again, shown in grey, the resulting power consumption and in blue the power conventionally consumed by GALAB.

In Figure 5-15, the course of cadmium telluride solar cells (cdte PV) is shown in black, which could have been achieved in the investigated period. The temporary maximum output of 17.6 kW is visible.

Figure 5-16 shows the power generated using polycrystalline silicon solar cells (poly PV), the course of which is shown here in orange. This type of solar cell could have generated a maximum output of approximately 21 kW during the time under consideration.

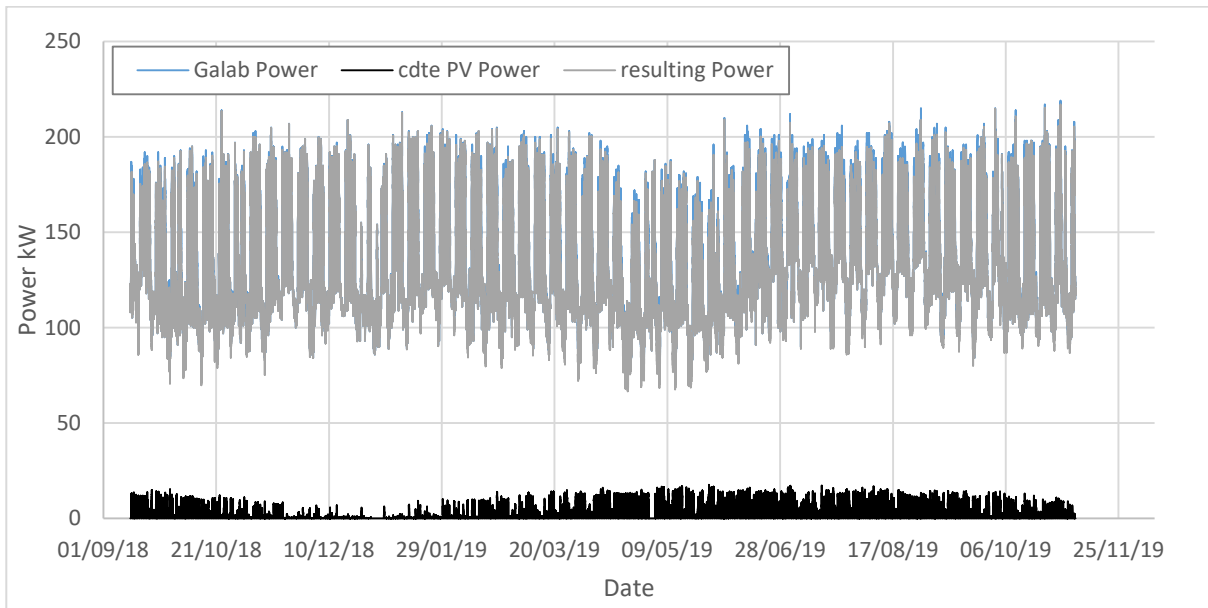

Figure 5-15: Use of cadmium telluride solar cells (source: own)

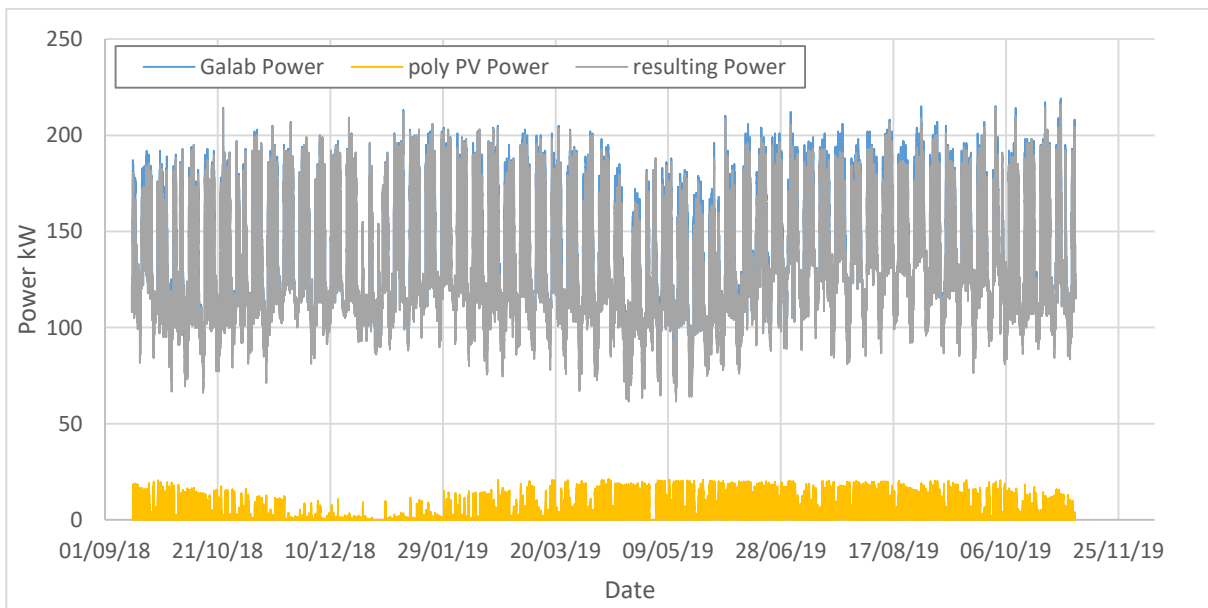

Figure 5-16: Use of polycrystalline silicon solar cells (source: own)

It is recognizable that with all types of solar cells examined here and in general with the use of a PV-system in the case under consideration, the power drawn from the grid can be reduced. In the period September to November 2018 and February to November 2019, a different output could have been generated depending of the type of solar cell, which could have been fed in relatively constantly during the day. In winter, the months from November to February, the value of the generated power decreases because the intensity of the sun and the duration of sunshine decrease during this period. However,

GALAB's grid consumption could also have been reduced by a certain amount in these periods. The solar cells of the copper indium selenium type have the highest power output.

The maximum load peaks, which influence on the performance price, the price which must be paid in order to guarantee the provision of high performances, remain, however, with all types.

Since the evaluation over the entire period from 2018 to 2019 only gives a rough overview of the situation that could have been achieved by using different PV-systems, two special cases are examined below. Firstly, the period in which GALAB's maximum power consumption from the grid prevailed. Secondly, the time in which the maximum output could have been generated by the solar cells is evaluated.

5.5.3 Investigation of maximum power consumption and maximum PV feed-in

The maximum consumption of electrical energy at GALAB in the period investigated took place in the week from 29.09.2019 to 06.10.2019. This period forms the basis for the following investigation, which is carried out in order to make a more detailed statement about the condition that could have been achieved.

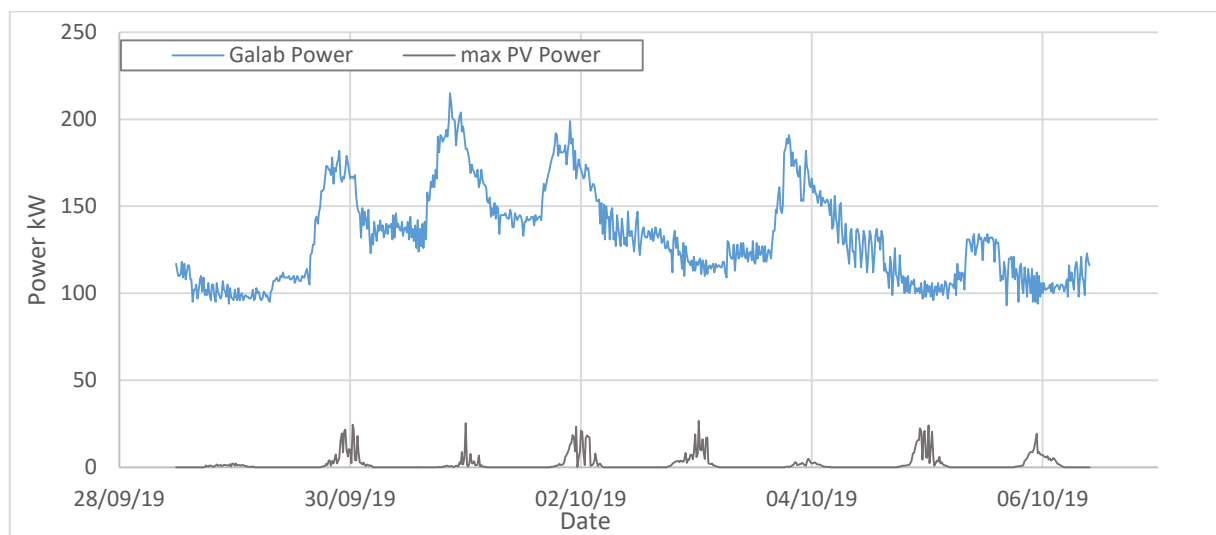

Figure 5-17, Maximal GALAB Power compared to PV Power input (source: own)

Figure 5-17 shows in blue the course of GALAB's power consumption, which reached its maximum of 215 kW in the period under consideration. The grey curve shows the maximum power that could have been supplied by the PV system during this time. It can be seen that the maximum power consumption prevailed at a time when no or only minor power could have been generated by the PV-system.

Figure 5-18 shows the course of performance on 01.10.2019, the day on which highest performance was taken from the grid by GALAB. The power consumed from the grid (shown in blue) increases continuously from around 4 am until it reaches its maximum of 215 kW at around 9 am. From this it can be concluded that the operation of GALAB begins during this time and that consumers such as the various measuring machines but also the light and office machines are started up. Then the power consumed is in the

maximum range until about 11 a.m. and then drops to the power consumed outside GALAB's operating hours until about 6 p.m. However, the theoretical PV-system would not have started to feed power into the system until around 10.30 a.m., after the maximum power consumption from the grid had been reached. While the PV-system produces power and feeds it into the system, the power consumption of GALAB can be reduced (see grey curve). However, this reduction of the received power is taking place, while the consumption of GALAB Laboratories is already decreasing. From this is to be deduced direct that a temporal flexibilization of the start-up of the plants in the laboratory or an intermediate storage of the power generated by the PV-plant would be necessary in order to effectively cut the resulting load peaks.

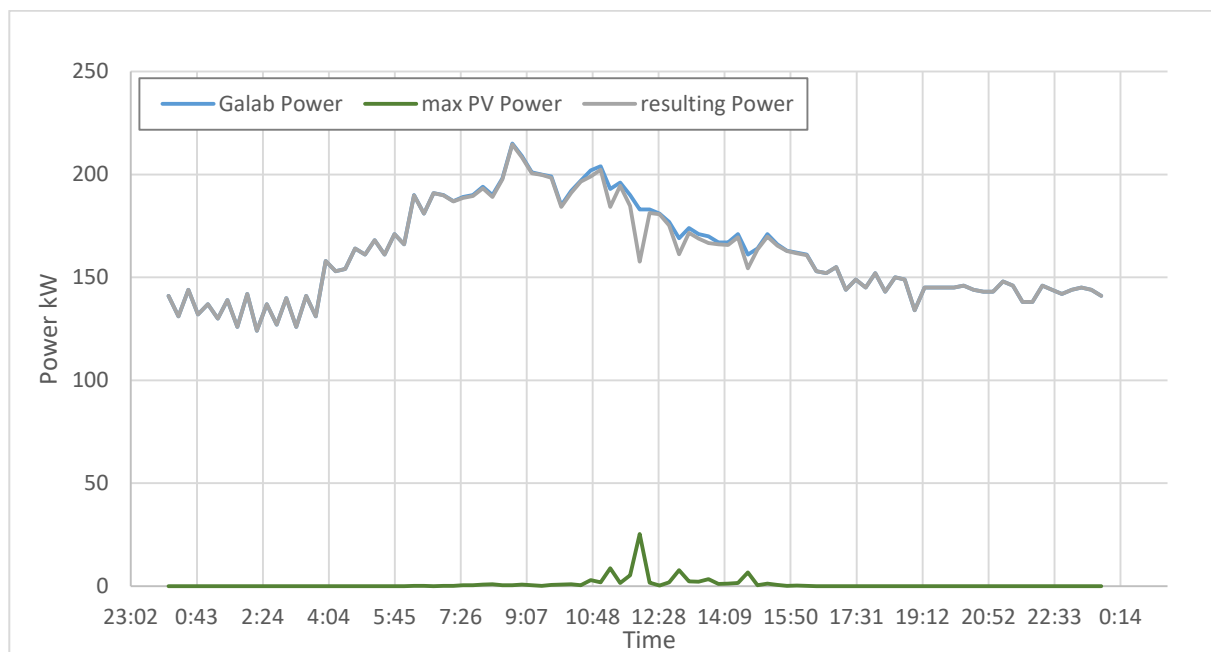

Figure 5-18: Day of maximal GALAB Power compared to max PV Power (source: own)

The curve shown in light green (Figure 5-19) shows the maximum power that could have been fed in, during the period under consideration. The result is that the resulting power, the power that still has to be withdrawn from the grid after deduction of the power fed in by the PV system, reaches its minimum in the case shown above (shown in grey). The power must continue to be withdrawn from the grid, meaning that operation at GALAB cannot be completely covered by the generated power of the PV-system.

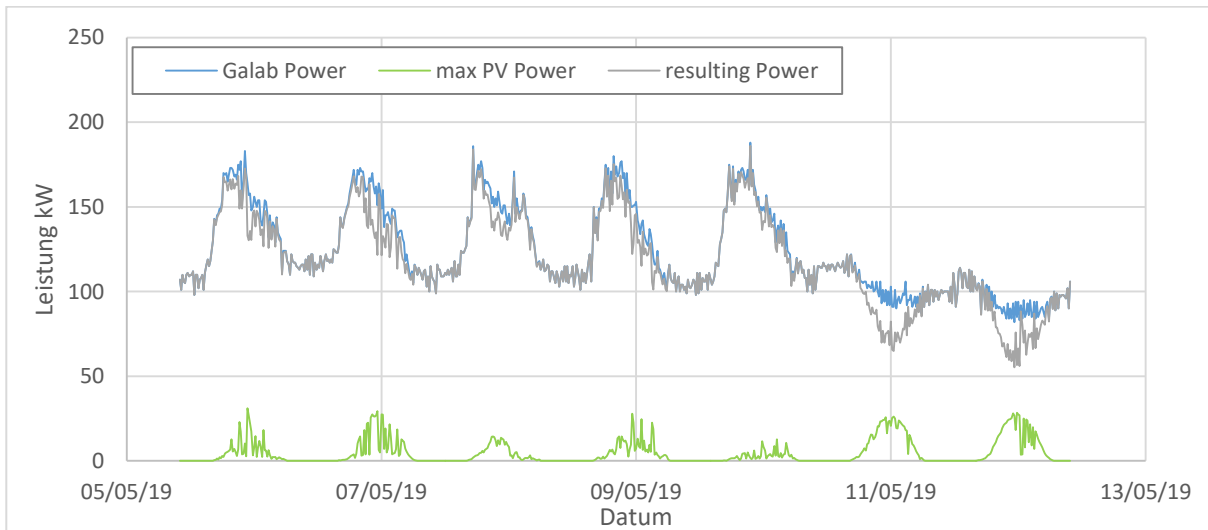

Figure 5-19, GALAB Power compared to maximal PV Power input (source: own)

Figure 5-17, Figure 5-18 and Figure 5-19 show that GALAB's power drawn from the grid can be reduced if the PV systems feeds in. However, the feed-in curves of the solar cells and those of the withdrawn power are not congruent in time. This means that the maximum output from the grid is already withdrawn before the PV output feeds in. This means that the cost-intensive and grid-intensive power peaks cannot easily be reduced using a PV-system. A temporal flexibilization of the power generated by the PV system would be necessary to effectively operate peak shaving.

5.5.4 Discussion of results

It can be concluded that the use of a PV-system at GALAB would indeed lead to a reduction in the output taken from the grid. In this way, the required output of the entire building can be temporarily reduced by up to almost 33 kW. However, these load reductions as a result of the PV feed-in do not occur at the same time as the load peaks of the consumption. A reduction of the grid-loading and costly power peaks would therefore not be possible by the sole use of a PV-system.

For example, a battery storage could be used to temporarily store the energy fed in by the PV-system and restore it at a later point in time in order to effectively shave peaks, which means to cut peak loads. Another possibility would be to reduce peak loads by shifting the load, for example by switching on consumers at different times. If the large energy demand of GALAB is distributed over the periods in which electricity from the PV system is fed in, the grid load and energy costs can be reduced.

Further investigations would have to be carried out to determine to what extent the two described variants are possible. Whether all systems must be available at the same time or whether there is potential for flexibility. Whether it is therefore possible to connect certain consumers with a time delay. The use of various additional systems, such as battery storage or future charging stations for electric vehicles, would also have to be critically scrutinized and investigated. The potential flexibility of the ice storage system

used by GALAB should not be overlooked. In addition, it would have to be investigated how great the energetic and monetary effects of such a load shift or load reduction by the PV-system and other additional systems would be. These open questions will be investigated in the further course, especially in the monitoring phase of the project.



6. Current status of the management and control strategies (Action 9)

6.1 Task Deskription

The objective of action 9 (Smart Energy Control in Smart Heating Islands) is the development of an innovative energy controller concept which will smartly control the different, in the district installed energy resources (e.g. CHP, PV, batteries, ice storage, heat pumps) to enable a local energy management aiming at a (as far as possible) CO₂ neutral energy supply within the area. One use case from this concept, here power and energy balancing on different levels (building to building level, quarter to quarter level), shall be implemented on the urban platform. The goal is, to maximize the use of locally generated energy within the neighbourhood instead of feeding it into the public grid. For management and controlling, a system-prototype is used and the task has to be classified in TRL 7.

Due to the current lack of available energy data sources from public or private buildings (as of 18.10.2019) we connected different facilities of the HAW University Energy Campus Building with the goal to monitor energy consumption and production, calculate and analyse trends and also create forecasts, thus supporting a power and energy balancing of a smart building in maximizing locally generated energy.

6.2 Prerequisites

Prerequisite for implementing the use case is the availability of the energy resources (installed within the newly constructed buildings) and, which is quite important, the agreement of the different stakeholders (data owners) to grant access to the data and to provide an interface to the data. The fact, that the most energy resources will be installed by parties, not part of the consortia, was always a risk. In the facilities of the Energy Campus, there are various energy sources available. For the mySMARTLife project, we have chosen three of the various energy sources available: Combined heat and power (CHP) plant, photovoltaic and mains. All of these facilities provide their current data sets via an MQTT-Broker. MQTT clients are able to subscribe to the topic of interest and get afterwards updates as soon as new data are produced in the technical facility.

The mySMARTLife Open Urban Platform consists of three parts: The Hamburg Urban Data Hub, the T-Labs Urban Data Core and the protocol gateway connecting both parts. Both platform parts, Hamburg Urban Data Hub and T-Labs Urban Data Core, have MQTT connectors acting as clients. They subscribe to the regarded MQTT-URLs of the energy facilities, get the data and store it in their attached databases.



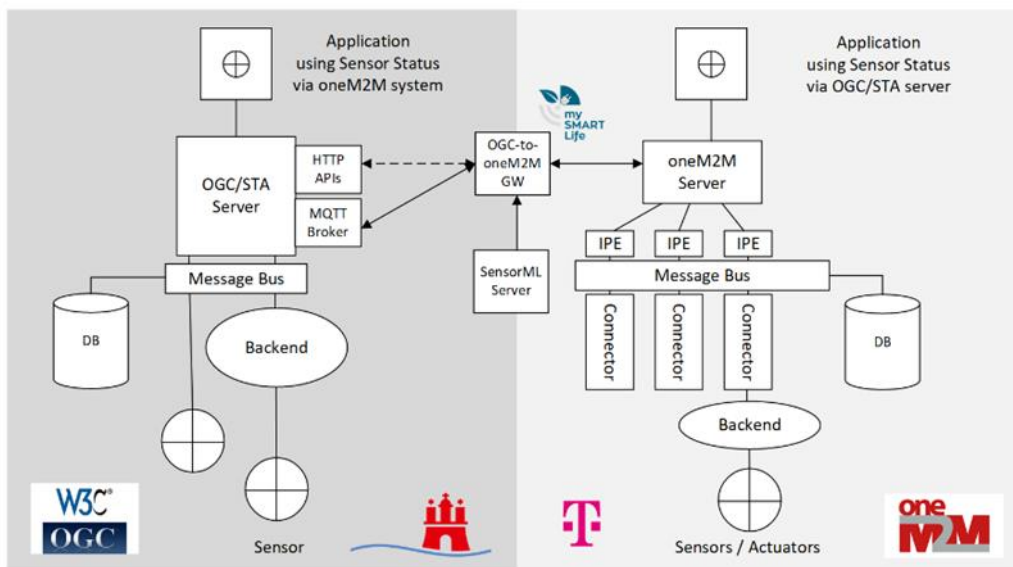

Figure 6-1: mySMARTLife Open Urban platform with its architecture parts and its integration

6.3 Current status

Energy data should be the same in both parts of the mySMARTLife Platform, in Hamburg and at T-Labs. So, it can be proofed that both sides are working properly and the SensorsThings API-to-oneM2M Gateway (as described in D3.5) as the connection between both platform parts is stable.

Currently, Hamburg Urban Data Hub as well as Deutsche Telekom/T-Labs Urban Data Core are connected to the HAW Energy Campus and testing via crosscheck, whether both platform parts are displaying exactly the same data. It is thus ensured that the integration of both architecture parts works stable and correct.

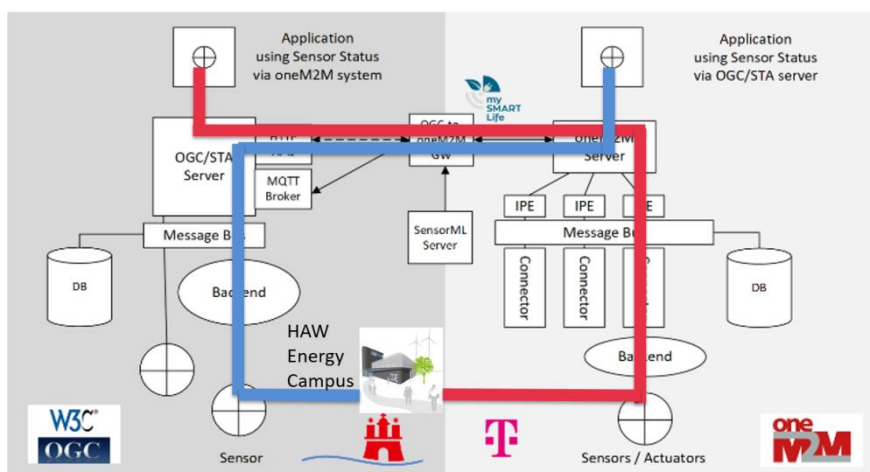

Figure 6-2: Gateway service test: Both sides get data via the Gateway service

Furthermore, we developed a user interface displaying information from the installed energy resources, namely from the electricity house connection, the photovoltaic system and the combined heat and power plant. The user can click on each of these three tiles to see the detailed status. The landing page (Figure 6-2) also shows the result of the Open Urban Platform's basic anomaly detection system, which continuously executing a system health check and alarms in case any anomalies found.

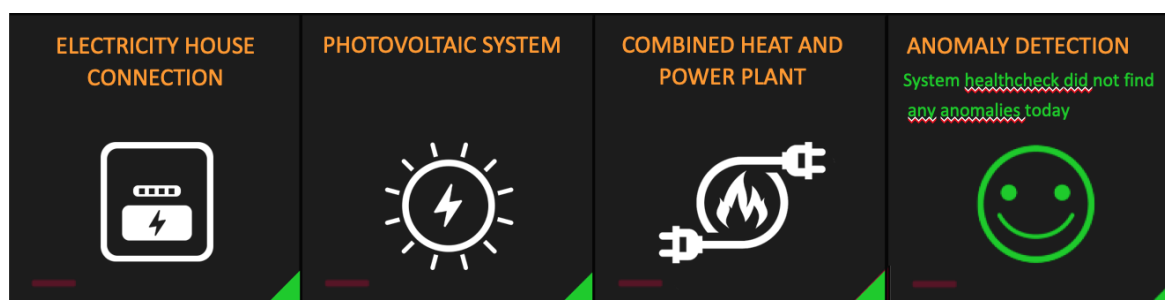

Figure 6-2: Landing page with anomaly detection status

The Electricity House Connection (Figure 6-3) indicates the current power delivered via mains from the regional energy provider. The CHP-plant tile shows whether the local plant is in operation and how much energy is generated and how much electricity is purchased from the electricity grid. Furthermore, current effective power, current reactive power and current apparent power are shown. The energy consumption of the current day and the entire year is displayed, and also the mains frequency and the used voltage.

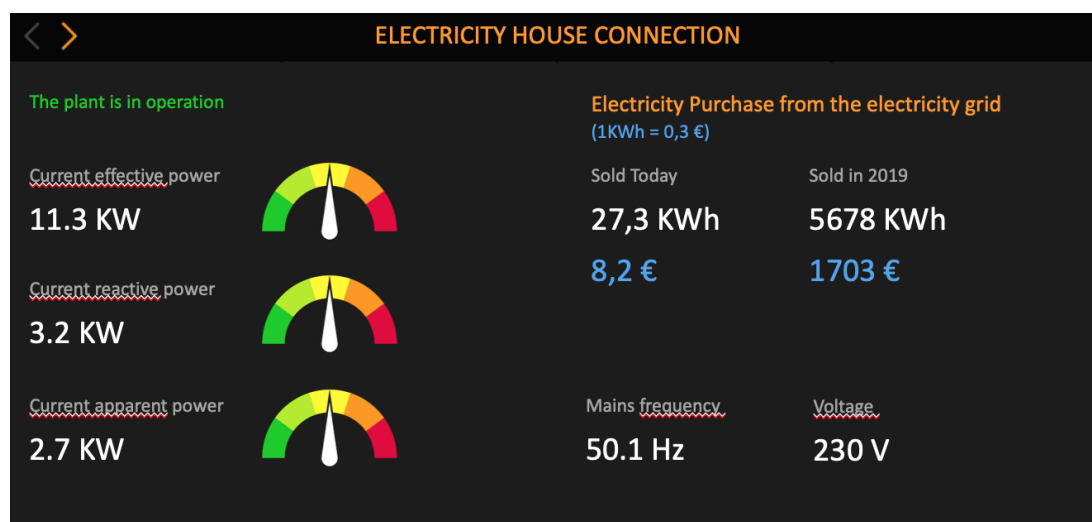

Figure 6-3: Status of Electricity House Connection

The Photovoltaic System status (Figure 6-4) shows whether the photovoltaic plant is in operation, what is it the current throughput and reactive power of the plant, how much power generated in the given day and since the installation of the plan. Also, it shows the monthly CO2 and cost savings for the given day, the given month and for the given year. Finally, the current temperature and solar radiation power - radiant energy currently emitted by the sun from such nuclear fusion reaction which creates electromagnetic

energy - is displayed, too. Using these two variables, the system is even able to create predictions, which can be useful information in terms of planning the usage of the non-renewable type of energy sources in the next couple of days.

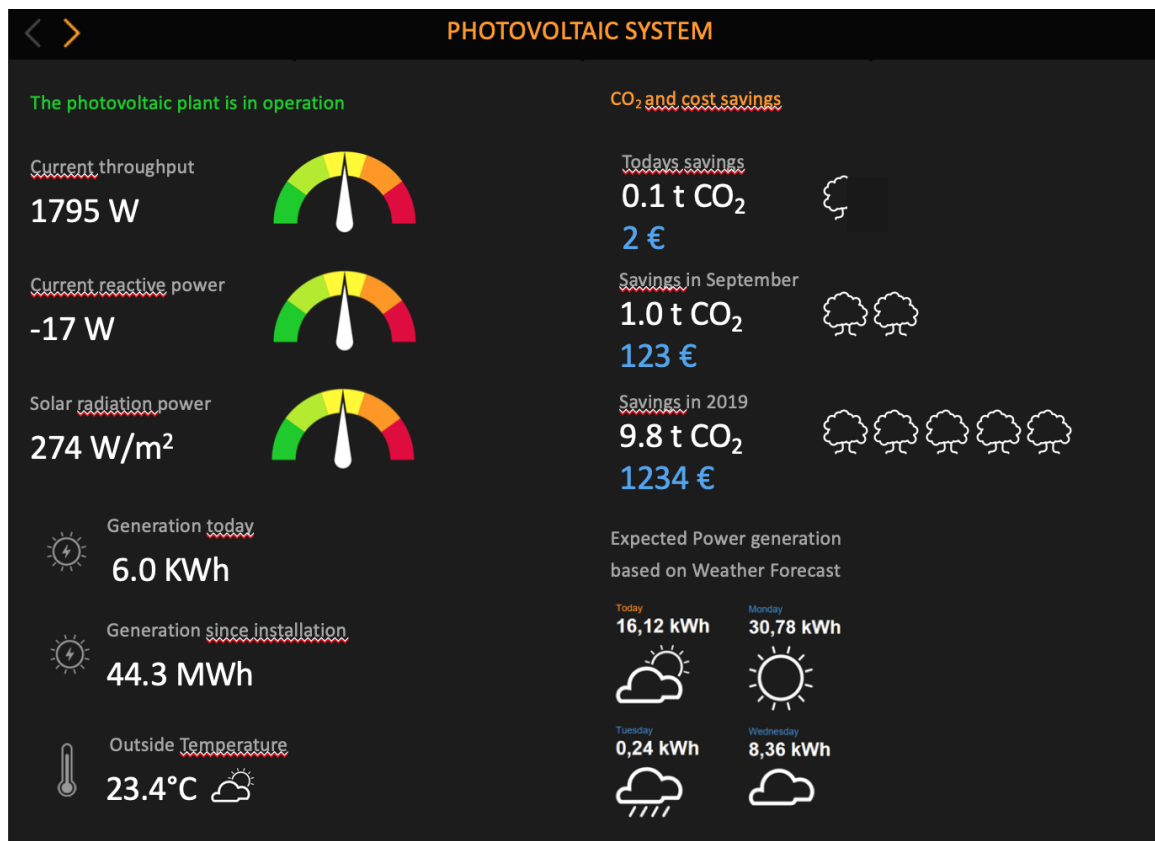

Figure 6-4: Status of Photovoltaic system

The CHP-plant status (Figure 6-5) shows whether the CHP-plant is currently in operation, if it was and for how long it was in operation mode. The current generation of electrical and thermal power and the sum of the generation during the day are depicted. Also, it shows how much energy needs to be drawn from the grid and how much energy is created with that and how much savings resulted from it in a given day, month and year.

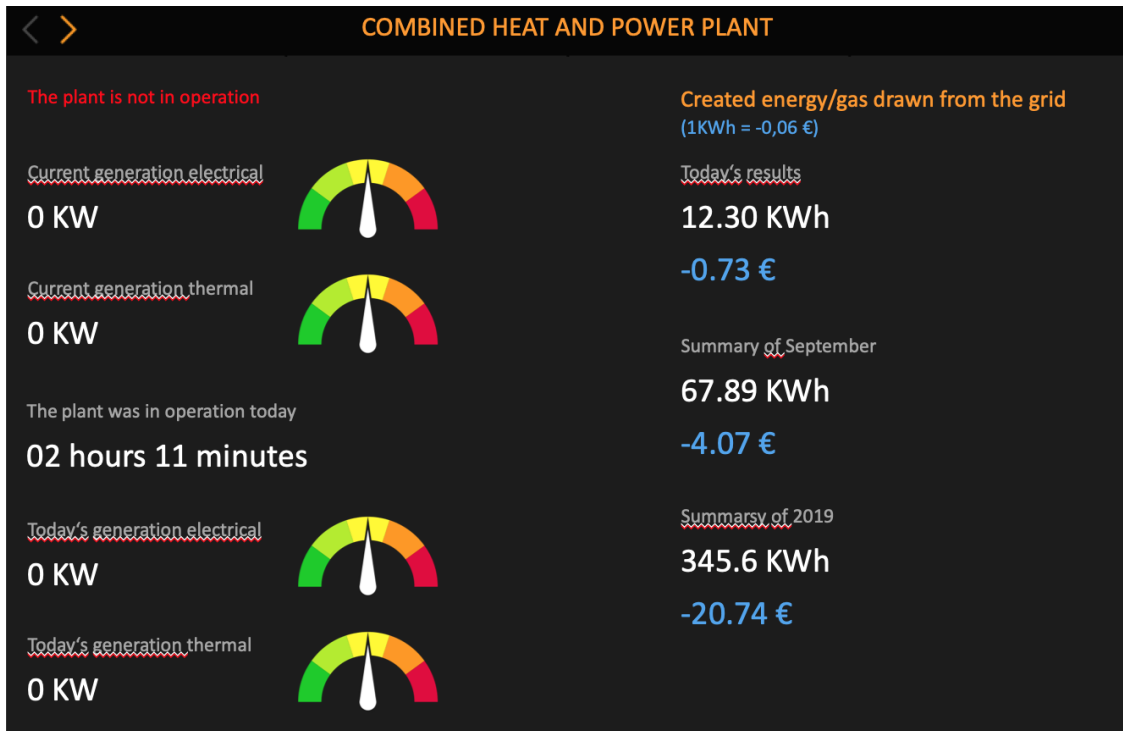

Figure 6-5: Status of Combined Heat and Power Plant

6.4 Key Findings

The mySMARTLife action 9 is about innovative controller concepts and Smart Energy Control in Smart Heating Islands. The initial idea was to use the different energy sources that are installed in the district. This was not possible because stakeholders outside the consortium did not permit access to the data sources. Therefore, we have chosen the facilities of the HAW University Energy Campus as data source. It is possible to process energy data by using open IoT standards like MQTT, SensorThings API and oneM2M. The dedicated energy sources publish their data in MQTT. The mySMARTLife Open Urban Platform orchestrates and publishes the data via OGC SensorThings API as well as oneM2M data sets. The exemplary application above shows the innovative usage of the data for local energy generation. Energy is produced respecting actual consumption and weather conditions, all by using open standardized IoT protocols. Furthermore, the whole setup is also used to proof the successful integrations of different architecture parts to a stable and reliable mySMARTLife Open Urban Platform. Everything is up and running at the end of the implementation phases.

6.5 Next steps

The next step is to get the required data from the Hamburg Urban Data Hub via the protocol gateway services instead of getting them directly from the Energy Campus. This will be done by the end of the mySMARTLife implementation phase. So, we are able to provide KPIs about the platform integration in terms of gateway availability, downtime, throughput etc. for the monitoring phase of the project.

7. Innovative Buildings

One main objective of the mySMARTLife project is the introduction of smart energy solutions. In the previous chapters different solutions for the generation of renewable energies are presented combined with strategies for a smart integration into the supply system of individual buildings, quarters or even larger areas, which is the case when grid services are considered. The following chapter focuses on different aspects of smart energy. With the implementation of a smart home assistant system and the roll out and installation of different modern measuring systems, the demand side in the topic of smart energy is covered in Hamburg within muSMARTLife too. The smart home system is implemented in retirement apartments and is combined with a care service. This combined approach adds an additional social aspect to the concepts of smart homes that not only allows conclusions regarding the functionality of the implemented technology.

Another aspect that is already addressed in the smart home action, but even more in the smart metering actions, is the idea to raise awareness regarding the personal energy consumption. The visualisation of energy demands is a key measure for this. Once the demand is visualised it is can easier to connect the personal energy consumption with the different actions in the household and eventually reduce the energy consumption. Different metering technologies were planned to be introduced in the project area in Hamburg-Bergedorf within mySMARTLife. Despite the efforts of the project partners, due to reasons that could not be influenced not all technologies can be installed within the project duration for reasons beyond their control.

7.1 Smart home assistant living

Against the background of a steadily aging society in Germany and in many parts of Europe, the smart home solution implemented in mySMARTLife focuses on two main aspects: to offer helpful services for elderly people in their daily life and to control and reduce the energy consumption of their main electricity consumers in their apartments. Furthermore, with the integration of household services, offered by trained people from outside of the regular labor market, a social aspect was integrated to provide an integrative approach to this intervention.

7.1.1 Evolution of the Task

From the start of the project, several meetings with local investors and housing companies have been conducted with the aim to promote the installation of smart home systems. The first attempt of the action was an implementation of smart homes at the new buildings in project zone 1, the “Schleusengraben area”, as a technical upgrade or service for possible tenants. Different aspects of smart home solutions have been discussed, like systems with deep integration in the buildings infrastructure. These should have helped to reduce energy consumption of households or included systems to organize community aspects,



such as car sharing or load management for e-cars. But none of the investors with ongoing housing developments were interested to install these systems and to bear the costs for the installation in their already good selling apartments.

Furthermore, some serious difficulties regarding the Hamburg budget law occurred. Since the installation of smart home systems in private apartments of citizens is not the ordinary task of the authorities, there were some barriers to implement this action for the Borough of Hamburg-Bergedorf as a public authority. The Hamburg budget law does not allow the Boroughs to grant subsidies to house owners or to grant technical products directly.

Thus, in 2018 a new approach for this action has been developed. Together with a local housing cooperative, the “Bergedorf Bille housing cooperation”, a new use case, with smart assistant systems for their elderly tenants, was identified and developed. Moreover, the “Sprungbrett Hamburg gGmbH”, a local company experienced in care services for elderly people, as a part of their labour marked activation activities, was called in and integrated in this action as the stakeholder. They agreed to buy and implement the smart home systems as partner within the mySMARTLife project.

With the approval of the 2nd Amendment in 2019 the “Sprungbrett Hamburg gGmbH” was integrated in the project as a new third linked party. The planning and actual implementation of the action could start in a short term in summer 2019.

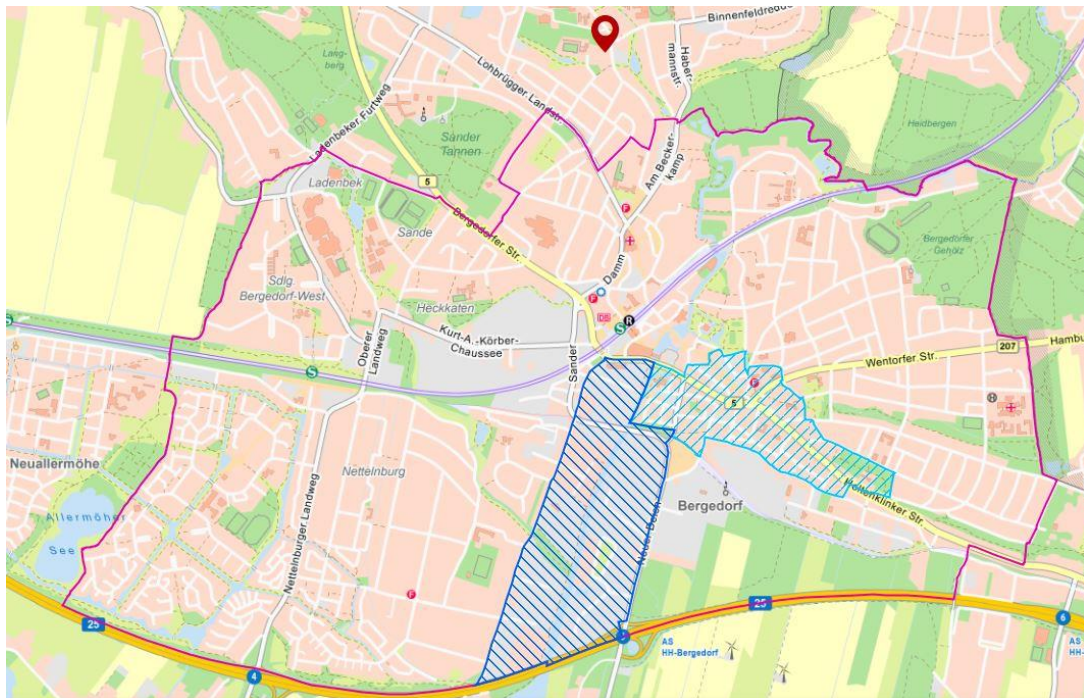

Figure 7-1: Location of the Bergedorf-Bille retirement complex at Leuschnerstraße 83a-f nearby the main mySMARTLife project area in Hamburg-Bergedorf, source: FHH-Atlas.

The first apartments, in which the smart home systems are to be installed in are part of the retirement complex by the housing cooperative Bergedorf Bille in the Leuschnerstraße 83a-f (Figure 7-1). The complex includes 81 apartments which have from 1.5 to 3 rooms with a living area between ca. 50 to 79 m². A standard 2-room apartment comprises a living area of about 59 m² (see Figure 7-2).



Figure 7-2: Impressions of the retirement complex at Leuschnerstraße 83a-f and a sample floor plan of a 2-room apartment, source: Bergedorf-Bille

7.1.2 Stakeholders involved in this action

After the adjustments of this action, the partners involved are now:

- the Borough of Bergedorf as the initiator,
- the housing cooperation “Bergedorf Bille”, which offers the contact to the tenants (their members),
- the company “Sprungbrett Hamburg”, which will do the implementation of the system in the apartments and offer the households services
- and the company “casenio” for the technical support and deployment of the data and communication platform.

Figure 7-3 provides an additional overview of the tasks of the individual stakeholders.

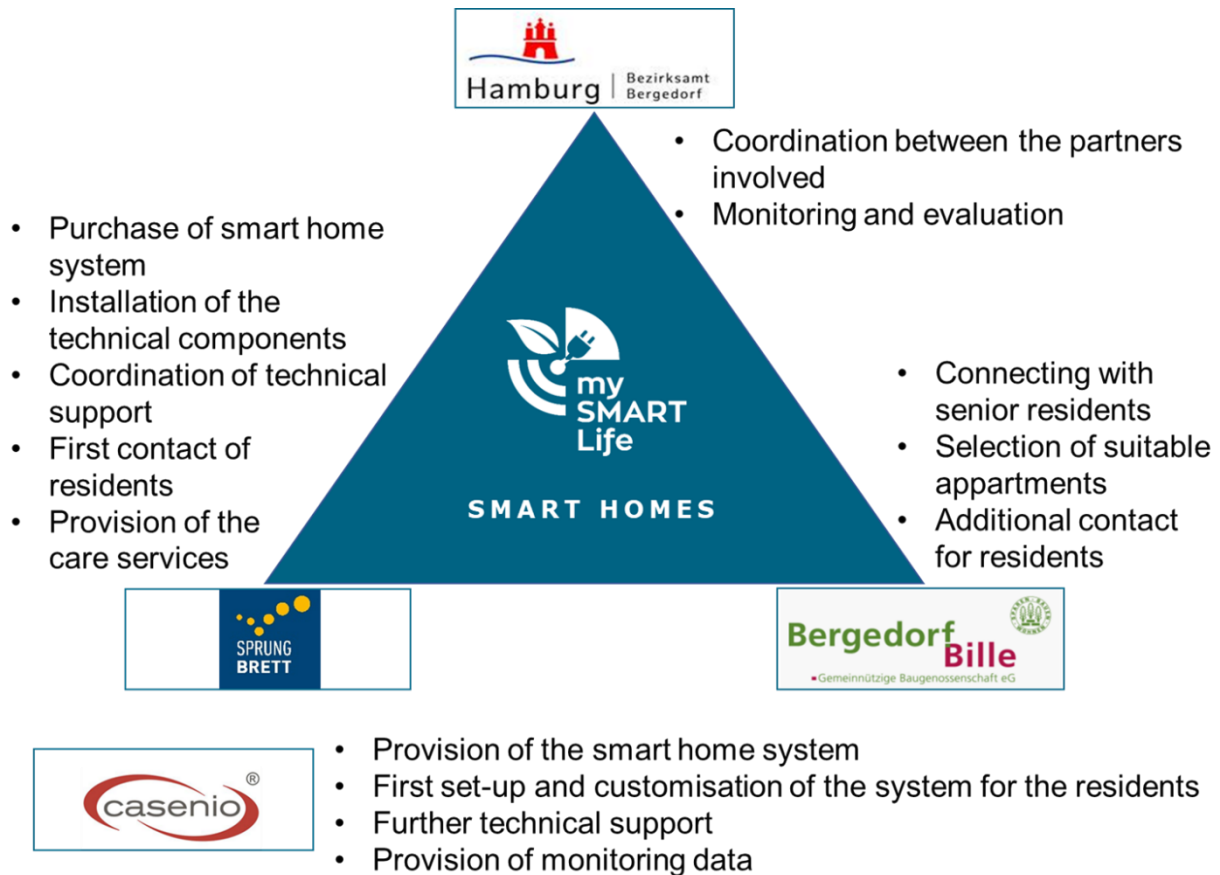

Figure 7-3: Scheme of stakeholders involved in the implementation of the smart home systems, source: Borough of Bergedorf, own source.

7.1.3 Advantages and the roles of the different stakeholders

The advantages for the tenants, the elderly people, are a gain of security and an expansion of independency in their homes. Sensors, such as the stove control, windows control and the help button, can be interconnected so that certain control and response schemes can be set up in the smart home system that for example should prevent the stove being left on unattended. Additionally, the system should allow a better overview of the main energy consumers in the apartments. The goal is to enable the elderly people to stay in their apartments and familiar environment as long as possible which is also helpful for the relatives. This should be achieved in the combination of the smart home system and the services offered by caretakers, the household helpers.

The advantages for the housing cooperative are a surplus of security for their apartments (building stock), a new service for their members (marketing and social benefits) and, because of the reduction of movements of residents, a decrease of relocation costs.

For the company “Sprungbrett Hamburg”, the household helpers are a new employment possibility to integrate people from outside of the regular labor market into the market again. This is one part of

Sprungbretts (re-)activation activities. The installed tablet offers a communication possibility for the elderly people.

For the City of Hamburg, the advantage is the gain of social connections and it is a new approach to deal with some problems of the demographic change in Germany towards an older society.

7.1.4 Technical description

The housing cooperative “Bergedorf Bille”, owner of approx 9,200 apartments and is willing to implement this action together with the project mySmartLife and has chosen the technical solution offered by the company “casenio”. This company is experienced in smart home systems for elderly people. The system, which is to be implemented here offers different services for the residents or their relatives such as:

- Smart living: intelligent light control, heating control, control of electrical appliances, functions for energy measurement, special functions when the person leaves the apartment.
- Security functions: protection against burglary, detection of water damages, fire detection, warning if the stove was forgotten to switch off the stove.
- More communication: information direct on the display, like news, dates, reminders for the garbage collection, contact to the caretakers.
- Integration of new business cases possible: additional offers of nursing services, arranging of room services, offers of telemedicine, online supermarkets.

It is a self-sufficient system with a home central, a tablet and linked sensors. No conversion measures, internet access or mobile phone are needed. The partners select the basic package from a list of possible components. In view of the limited resources available, this system should consist of a series of sensors, which would allow the installation of as many systems as possible, while providing real benefits for the residents. Against the background of limited funding, this system should comprise a number of sensors that both enable the installation of as many systems as possible and at the same time, mean a real gain for the residents. Furthermore, the layouts of possible apartments have been analysed to calculate the right number of sensors. The components, which have been chosen for the package, are:

- a home central to collect the sensor data
- a Wi-Fi-tablet as communication tool
- 2 multi-sensors (door, movement, light, temperature)
- 1 door and window sensor (balcony door)
- 3 socket adapters for energy measurements and control
- 2 multisensory (temperature, air humidity)

- 1 stove control with temperature measurement
- 2 radiator thermostats incl. temperature measurement and digital display

The TRL of the smart home system needs to be considered as 9. This system, as it is used here is already available on the market and used in similar environments. Yet, with the combination of a care system, as it is done in mySMARTLife in Hamburg-Bergedorf, the TRL is below 9. After the system is installed in the households, it needs to be evaluated, whether this combination is beneficial and also practicable for the residents. Then the partners decide if they will pursue this approach beyond the project's duration and transfer this system to other areas or modify it, so that other user groups can be addressed as well. The following picture shows an example package with a display, a motion detector, alarm buttons and more.



Figure 7-4: Example of a smart home set from casenio, source Casenio

The visualisation of the largest energy consumers in the households, such as the TV, fridge or washing machine, should help to raise the awareness regarding the own domestic energy consumption and eventually lead to an energy-saving user behaviour. Moreover, automated control settings, which can be selected with the different sensors and controllers should help to lower the energy demands, when certain devices will be turned off or when the heater is lowered once the residents leave the apartment. These automated settings should also help to increase the security of the residents, whereas an alarm message can be sent to relatives or other people when some pre-set incident happens, e.g. the apartment door was not opened for a certain amount of time or the like.

7.1.5 Financing of the implementation

The purchase of the first systems will be paid with funding of the mySMARTLife project (about 1,500 € per apartment), only the installation of the stove control from an electrician is paid by the housing cooperative.

The training of the household helpers is paid with national labour market funding. The hours of services for the elderly people can be paid by their insurance when they have care level 1. Otherwise they have to pay for the services on an hourly basis.

7.1.6 Implementation plan

The implementation of the action is still ongoing. After the Amendment, which included the reorganization of this intervention, was approved, the responsible partners started directly with the implementation. Since the Bergedorf Bille housing cooperative maintains a very good and direct contact to their cooperative members, some suitable housing estates with nearly exclusively senior living could be identified and the tenants be addressed.

When the elderly residents were addressed, it was ensured, that this was done via the established channels and formats of the housing cooperative. This was done in order to avoid any possible fears of the new technology. Altogether, by October 2019, two information events were accomplished, in a neighbourhood meeting place of the cooperative, additional smaller events are planned for the following months. At the first meeting on 22/08/2019, 81 tenants were invited and 17 people attended the event, of whom 14 households expressed interest in a smart home system. At the second event on 08/10/2019, 335 tenants were even addressed and 48 tenants appeared, 32 households expressed interest.



Figure 7-5: Information event at a local community centre of the housing cooperation, source: Borough of Bergedorf. In the next step, the tenants who have expressed interest are contacted and consulted separately by the partner Sprungbrett. A date for the installation of the system is agreed upon together.

During the information events the tenants were also informed, that this measure is part of an EU research project and that during the monitoring phase the collected energy data of the consumers will be evaluated anonymously by the project. They were further informed that the HCU as well will address the users of a

smart home system, in the context of a social acceptance study. The approval of these two research points is a prerequisite for such a smart home system.

After the first information phase, the installation of the systems in the individual apartments begins. There is a fixed division of labour: The plug-in sensors will be set up by employees of the partner Sprungbrett, the company casenio will integrate the central data platform for the smart home systems. The installation of the stove control is carried out by electricians commissioned by the building cooperative.

In addition, the partner Sprungbrett has opened an office close to the area, in order to coordinate the services of the caretakers and to establish this office as a first service centre for the smart home systems. The general technical support, however, will be still provided by the company casenio. A schematic overview of the development and implementation with the different partners involved can be seen in Figure 7-6.

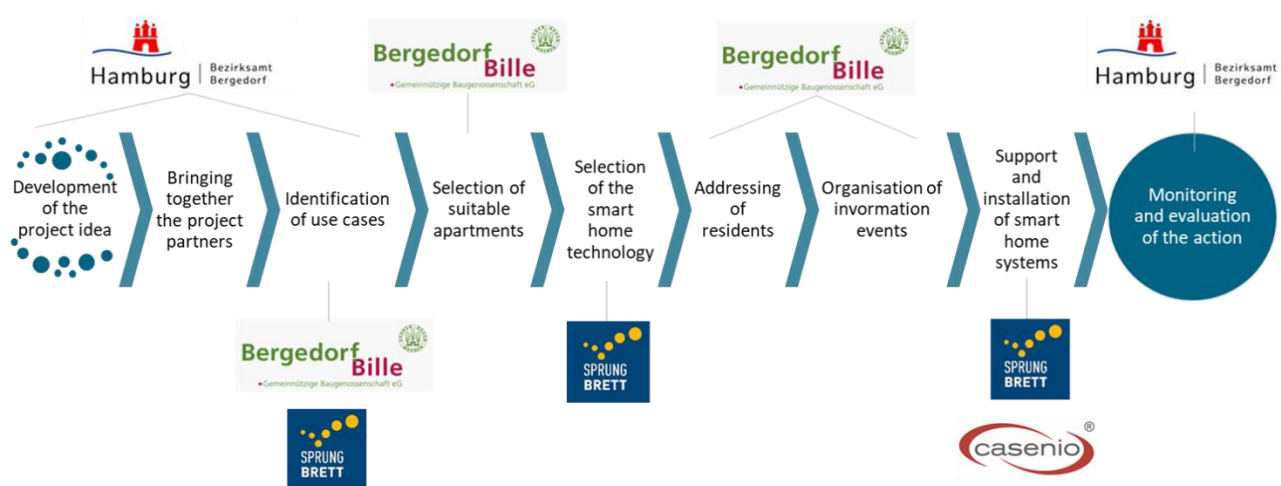

Figure 7-6: Development and implementation scheme of the smart home action with the main contributions by the stakeholders (source: Borough of Bergedorf, own source).

7.1.7 Main challenges during the implementation

Some difficulties and challenges in the coordination and implementation of this action were caused by the late approval of the amendment, as described above. Due to the budgetary problems to grant the subsidies, it only was possible to start with the action, after the approval of the amendment and with the inclusion of the new partner Sprungbrett (SPB) in June 2019.

With regards to the technical implementation, the high installation costs have been a major obstacle for many systems which were initially examined. Systems, which are permanently installed in apartments usually require a deep technical intervention in the house infrastructure, in particular by installing sensors in the wall or by the required replacement of fuse boxes and electricity meters. Whereas some systems also require a special wiring which is usually done alongside the electric wiring in new constructions. These installations must be carried out by electricians, which extremely rise the costs for the apartment

owner. In addition, there is a high expenditure of time and a stressful construction phase for the tenant. A further problem with the installation of smart home systems in existing buildings, is that the old apartments usually have a wide variety of electrical infrastructure and are not uniform, which contains another cost risk. Many apartments still have outdated wiring systems or fuse boxes that need to be replaced by the owner, before a smart home system can be installed. At the same time, the housing cooperative is demanding standards for technical equipment that should be installed (e.g. CE label, VDE label). Yet, not all suppliers on the market have their products tested or certified at the different testing institutes.

Because of the reasons mentioned above, the partners of this intervention have decided to use a plug-in system that avoids many of these problems. In addition, the installation and the removal of the systems is very flexible. So large, cost-intensive interventions in the building infrastructure can be avoided and the risks for the partners involved or the residents is minimised in case the system needs to be removed.

7.1.8 Conclusions and main benefits

The main aim of this action is to lower the barriers for landlords and tenants, to promote the dissemination of smart home systems as a future infrastructure in the smart city. With the focus on the age group of senior citizens and the integration of the everyday helpers into this technical action, a smart contribution to the problems of an ageing society in Germany became a further focal point.

It has shown that the focus on a specific use case (smart homes for elderly people) was very useful during the implementation of the action. At the same time, however, it needs to be recognized that this area does not represent a typical field of action for the administration, as a citizen's home is a protected area. This focus group made it even more important to lower the complexity of the system that should be installed. The field of smart homes includes a large number of different possible systems and applications. The pre-selection of a basic package, which was put together by the project partners who partly have extensive experiences working with elderly people, reduced the complexity of the system and hence helped to reduce communication efforts and accelerate the implementation.

Since the most parts of European cities are already built and will only be used further in the future, the use of easy-to-install systems (Plug-In and Plug-Out) is an important success criteria. The existing housing stock can thus be used more flexible and will be technically upgraded. The seniors can stay longer in their familiar social environment and the number of moves between apartments can be reduced.

Furthermore, the integration and close coordination of the cooperative have proven to be helpful and have contributed significantly to the successful implementation of the action. The cooperative supplied important insights to its tenant's structure and referred to the problem of the constantly aging members.

With their good contact to their members and well-established communication channels, they have contributed significantly to the marketing of the systems and have achieved a high resonance among the

cooperation members. Due to that, high expenditures for advertising, to address the tenants and to convince them to install such a system, which is normally a problem, was avoided here.

In the following months, the monitoring will show whether the elderly residents will see the smart home system as a benefit for their everyday life and if it will have an impact on their energy consumption. A reduction is expected through an increased awareness of the own domestic energy consumption through the visualization of the large consumers and better control of the heating and ventilation. In general, however, the topic of smart homes is an interesting topic in the project, whereas this is one of the few areas where citizens are in direct contact with smart infrastructures.

7.2 Smart metering

7.2.1 Implementation of modern measuring devices and in-house Visualization

In the project area 2,000 smart metering systems (modern measuring devices) will be installed in the project area. The modern measuring device is the latest technology for counting electricity consumption. So, this task is on the TRL 8. The basis for the introduction of modern measuring equipment is the law on the digitization of the energy transition. The German legislator wants to achieve the goals of the energy transition with the introduction of modern measuring equipment. An important goal of the energy transition is the improvement of energy efficiency. The modern measuring device enables a more conscious use of energy. The former technology only allowed reading the current count. In addition to the current power consumption, the modern measuring system also shows the daily, weekly, monthly and annual electricity consumption values of the last 24 months. The use of an interface via optional adapter is possible. Although the technology is very new, modern measuring equipment is already available from manufacturers are available from the manufacturer since May 2018. So more than 2000 modern measuring systems have been ordered by Stromnetz Hamburg. A quality-assuring incoming goods inspection was carried out and the measuring instruments were released for installation. Subsequently, the orders to change the measuring equipment were created and arranged from conventional to modern. Between October 2018 and April 2019, more than 2,000 conventional electricity meters were replaced by modern measuring equipment in the project area.



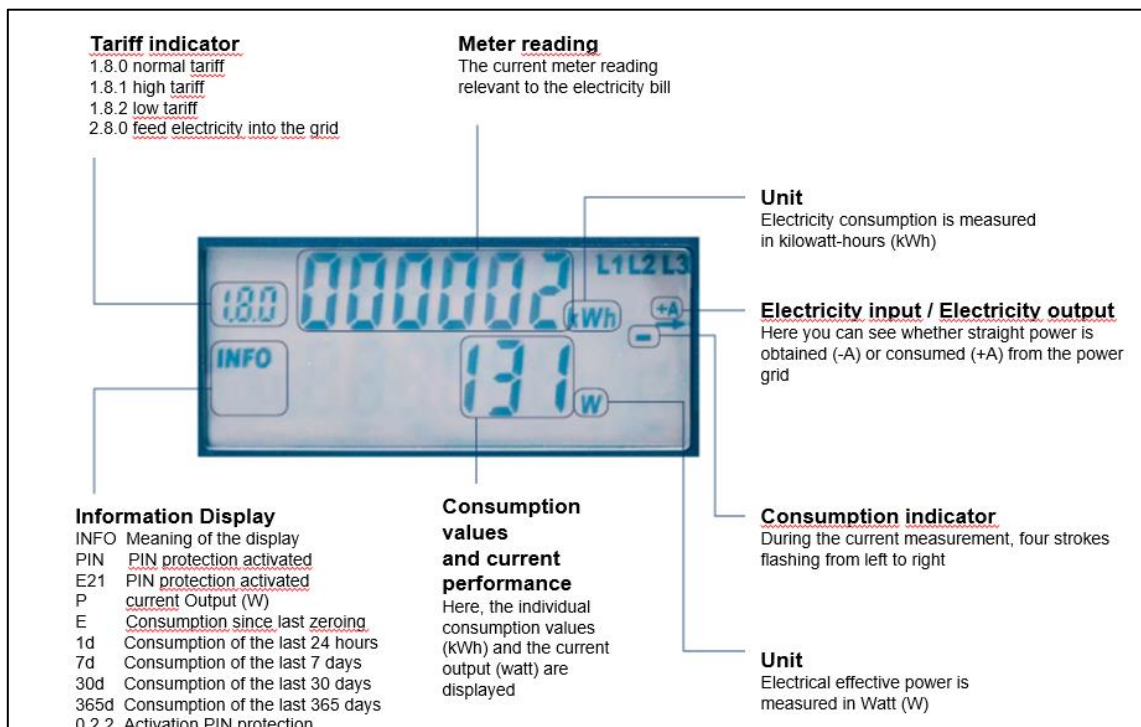

Figure 7-7: the display of the modern measuring device, source: SNH

There was no deviation from the original plan for action 10. The budget was required for the following: 1. For the technical staff, to test the modern measuring equipment. 2. For the use of logistic personnel, to ensure procurement and to negotiate supply contracts. 3. For the deployments of operational staff, to drive roll-out planning for modern measuring equipment in the project area. 4. For the use of field staff, to exchange conventional measuring technology on site with modern measuring equipment

The technology of the in-house Visualisation via the modern measuring system is shown below:



Figure 7-8: technology of the in-house Visualisation, source: SNH



Figure 7-9: Short-time and Long-time History, source: SNH

The modern measuring device has a data interface for the customer. Via an adapter, consumption data can be read out via the data interface with a computer / mobile phone. The adapter makes it possible to read out current measurement data from electricity meters, store them and transmit them in IP format. The readout adapter is attached to the infrared interface of the meter and has a fixed LAN cable for connection to an IP network. Via an integrated web server, which can be addressed via LAN, the recorded measurement data can be downloaded and settings made. Power is supplied via the supplied power supply. The maximum resolution is in the second range.

As an alternative to the web interface, the current energy consumption can be tracked at any time with the free app “Strokomo!”. Data received via the DvLIR, is processed as consumption histories and clearly displayed. The data is not accessible to the servers of Stromnetz Hamburg GmbH. It is a pure in-house visualization.

The adapter for in-house visualization was developed in cooperation with Stromnetz Hamburg GmbH and Device GmbH. More than 200 adapters were installed from December 2018 to March 2019 for customers in the project area.

The budget for the in-house visualisation was required for the use of technical staff for the development of the adapter with cooperation partner Device GmbH. Also, for the internal staff to install the adapters at customers and to carry out a first briefing.

This action allows inhabitants of the project zone to visualize their consumption and so allow them to reduce consumption by changing their consumption behaviour. Further, latest technology is being implemented in the project zone.

7.2.2 Implementation of advanced measuring systems in the project area

It was planned to implement 500 advanced measuring systems in the project area. This technology is in the test level and to score in the TRL 4. The picture below gives an idea how the system would look like.



Figure 7-10, advanced measuring system, source: SNH

The system is a combination of modern measuring equipment and the communication unit "Smart Meter Gateway" (SMGW). It is supposed to allow online visualization of consumptions (15-minute time intervals) and counter readings. Users could benefit from variable rates from the supplier. The supplier could influence consumer behaviour in favour of production and distribution by appropriate adjustment of supply and demand.

Obstacles and Result:

The Federal Office for Information Security (BSI) has defined the security standards for the data transmission of intelligent measuring systems. The communication units of the intelligent measuring system may only be used once the BSI has certified these communication units. This must be done by law by three independent manufacturers before installation is allowed to commence. Currently the certification is still ongoing. According to unconfirmed data, this will not be completed until 2020.

At present, the Stromnetz Hamburg GmbH only can observe the certification process by the Federal Office for Information Security.

Thus, the action is stopped.

7.2.3 Implementation of multi metering in the project zone

It was planned to implement 200 multi metering units in 200 residential units in the project area. TRL is 8. The picture below shows the functionality of the system:

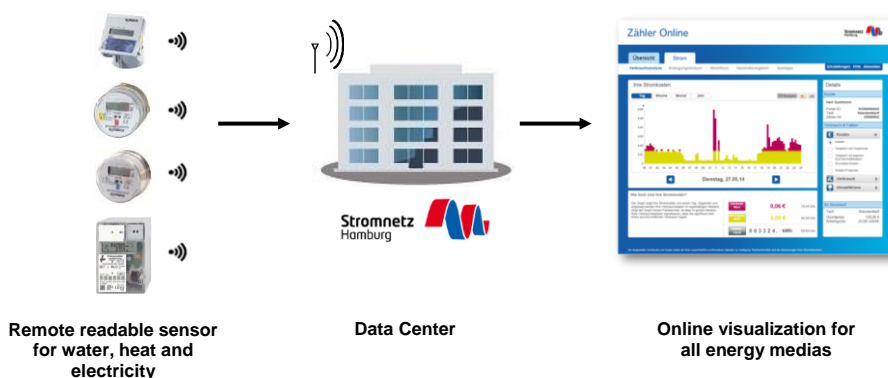

Figure 7-11: system functionality of multi metering system

Multi Metering allows combined remote reading of all energy media in an apartment. Further, it allows online visualisation for the home user including cost management.

The budget for this measure will be used by administrative staff to discuss the introduction of multi-metering with potential investors. If we will find interested investors within the project zone, we will activate technical, operational and field personnel to equip the object of the project. Additionally, a service partner will be hired for the installation of the meters.

Obstacles and Result:

Since many buildings in the project zone are not built, there was no investor who is willing to participate in the project. The action “Multi Metering” will not be realized.

7.2.4 Conclusion Smart Metering

Smart metering leads to a higher transparency about your own energy consumption. This does not mean that this automatically results in a saving effect. Rather, transparency is a tool that the customer can proactively analyse its own consumption and initiate measures to reduce energy consumption and / or costs. One could also say that transparency is the necessary basis.

Unfortunately, two project points could not be completed. On the one hand, this involves the use of the intelligent measuring system. Unfortunately, the German legislature has not yet given any valid permission to operate those systems during the project period.

In addition, multi metering is not implemented within this project. The buildings intended for this purpose have not been built during the project period. However, multi-metering is already successfully in use in other projects in Hamburg.

8. Discussion of the results (till M36)

The low-ex district heating cannot be implemented in consequence of the decision of the investor. It is often observed, that innovation and environmental protection do not play a roll in the independent real estate market. Although the investor signalled in preliminary discussions the willingness to cooperate and to implement the solution, he ultimately decided against the innovative low-ex concept in favour of a cheap standard solution. Despite project financing from the project, the low-ex heating network is not in a position to compete on the market with a cheap standard solution on the market. As a result of this experience, an expert plan "Energy" is currently being developed by the City of Hamburg, which defines the requirements for future urban building projects.

In the windfarm, the demonstrators could be set up within the planned timeframe. A one-year test phase with the wind farm was successfully implemented and the data connection from the wind farm control room to the TCEC and the setup of the monitoring are set. As part of the Sinteg project, NEW 4.0, innovative system services (instantaneous reserve, primary control, and reactive power management) are carried out and evaluated in combination with the wind farm and the battery.

The expansion of PV-systems on roofs of existing tenements and commercial buildings with the corresponding electricity supply concepts is progressing very slowly. The house-owners do not show a strong interest because it is not profitable for them. However, they commit themselves in the long term of 20 to 25 years to provide their roof for the PV-plant. At the moment there are limits to the building alterations. At least, tenants are interested in both – energetic restoration and green electricity power delivery from the roof but the house-owners are not. These circumstances make it difficult to acquire roofs and to initiate restoration. For this, a combined public funding program would certainly be meaningful, in which an energetic roof retrofit is combined with the implementation of solar systems and tenant electricity concepts.

It has shown, that the deployment of smart home solutions is a completely new field of activity for the municipality. To this day, the apartment of a citizen is considered more private than an area of urban development. For this reason, the district has sought the cooperation with a housing cooperative in order to benefit from its experience and to ensure the operation of the smart homes after the project. Also, the housing cooperation suggested to combine the topic of smart homes with the specific use case of assistance for seniors, in order to achieve a higher acceptance of the systems among users. The cooperation with the social company "Sprungbrett Hamburg" has made it possible to get into a positive contact to elderly people. That was the prerequisite for getting the people interested in technology and showing them the benefits. The procedure for the decision-making of the possible users is time-consuming and the implementation is going on.

The delays and obstacles to smart metering also make it clear that the current legal situation can block the way for the introduction of new innovative technologies for the energy transition. Approval procedures take rather long in Germany. This concerns the approval of technical equipment as well as the approval of new wind turbines. There is a need for change here in the interest of climate protection..

The IT area of management and control strategies is also hampered by the fact that planned buildings were not built during the project's lifetime and the investors in the converted buildings did not have access to their data. For this reason, the available data from the HAW energy campus were used as a basis. Monitoring will also integrate the production data of the ENH PV-plants.

In total, the experiences in implementing of energy actions in mySMARTLife in Hamburg have shown that the current cost structure of the energy market makes it difficult to install renewable energy installations. In particular, the enormous electricity price discounts for large consumers justify that PV systems are not economical for these consumers. Therefore, we can only implement part of tomorrow's innovative energy generation and intelligent energy management options.

The challenges of the project did also show that the asset market is not ready for the widespread implementation of these innovative techniques and that the further spread requires first political positioning and reliable funding, so that these technologies would become the normal case.

9. References

- [1] Arbeitsgemeinschaft konsalt GmbH, MegaWATT GmbH und Metropol Grund GmbH (2014): Energetische Stadtsanierung Bergedorf-Süd. Available at: <http://konsalt.de/wp-content/uploads/2014/06/2014-02-17-Endbericht-Bergedorf-Sued.pdf> [13.11.2018].
- [2] Arbeitsgemeinschaft konsalt GmbH, MegaWATT GmbH und Metropol Grund GmbH (2017): Energetisches Sanierungsmanagement Bergedorf-Süd. Available at: <http://suche.transparenz.hamburg.de/dataset/endbericht-zum-energetischen-sanierungsmanagement-bergedorf-sued> [13.11.2018].
- [3] Bundesministerium der Justiz und Verbraucherschutz. Erneuerbare Energien Gesetz – EEG. Available: http://www.gesetze-im-internet.de/eeg_2014/index.html [20.11.2018]
- [4] Bundesministerium für Umweltschutz, Naturschutz und nukleare Sicherheit. Klimaschutzgesetz. Available: <https://www.bmu.de/faqs/klimaschutzgesetz-vom-9-oktober-2019/> [28.11.2018]
- [5] Bundesministerium der Wirtschaft. Gesetz zur Förderung von Mieterstrom und zur Änderung weiterer Vorschriften des Erneuerbare-Energien-Gesetzes. Available: https://www.bmwi.de/Redaktion/DE/Downloads/M-O/mieterstrom-gesetz-bgbl.pdf?__blob=publicationFile&v=4 [20.11.2018]
- [6] Bundesministerium der Wirtschaft und Energie. Energiesammelgesetz. Available: <https://www.bmwi.de/Redaktion/DE/Artikel/Service/Gesetzesvorhaben/energiesammelgesetz.html> [20.11.2018]
- [7] Bundesministerium der Wirtschaft und Energie. Kohleausstiegsgesetz. Available: <https://www.bmwi.de/Redaktion/DE/Pressemitteilungen/2019/20190704-bmwi-legt-rahmen-der-kohleausstiegsgesetzgebung-vor.html> [28.11.2018]
- [8] DGS Deutsche Gesellschaft für Solarenergie e.V. Oberzig, Klaus. 2019. Kohleausstiegsgesetz - Schlachtplan gegen die Erneuerbaren (Commentary on the Coal Exit Act). <https://www.dgs.de/news/en-detail/221119-kohleausstiegsgesetz-schlachtplan-gegen-die-erneuerbaren/> [28.11.2018]
- [9] FHH (Freie und Hansestadt Hamburg) (2014a): Grüne, gerechte, wachsende Stadt am Wasser, Perspektiven der Stadtentwicklung für Hamburg
- [10] FHH (Freie und Hansestadt Hamburg) (2015): Hamburger Klimaplan, Drucksache 21/2521



- [11] FHH (Freie und Hansestadt Hamburg) (2014b): Energiewende made in Hamburg. Available: <http://www.hamburg.de/energiewende/energiewende-in-hamburg/3737996/hamburger-energiewende/> [11.07.2016]
- [12] FHH (Freie und Hansestadt Hamburg) (2015): Solaratlas. Available: <https://www.geoportal-hamburg.de/Solaratlas/index.html#> [15.11.2019]
- [13] Fraunhofer-Institut für Solare Energiesysteme ISE. https://www.ise.fraunhofer.de/content/dam/ise/de/documents/publications/studies/daten-zu-erneuerbaren-energien/ISE_Stromerzeugung_2019_Halbjahr.pdf [07.11.2019]
- [14] Mecanoo Architekten, Bezirksamt Bergedorf, Internationale Bauausstellung IBA Hamburg GmbH (2010): Masterplan Schleusengärten Hamburg Bergedorf
- [15] Nordex SE. http://www.nordex-online.com/fileadmin/MEDIA/Gamma/Nordex_Gamma_en.pdf [15.11.2019]
- [16] Statistikamt Nord. Zahlen und Fakten. Available: <https://www.statistik-nord.de/zahlen-fakten/> [20.11.2018]
- [17] Umweltbundesamt (Federal Environment Agency). Energieverbrauch für fossile und erneuerbare Wärme. Available: <https://www.umweltbundesamt.de/daten/energie/energieverbrauch-fuer-fossile-erneuerbare-waerme#textpart-1> [07.11.2019]

10. Appendix

Table 10-1: Solar irradiation data Hamburg Demonstration Site of potential Analysis

| No. in map | radiation density [kWh/m ² ·a] | pot. -PV Area [m ²] | pot. PV peak power [kWp] | pot. PV yield [MWh/a] | CO2 reduction [Mg/a] | pot. thermal collector area [m ²] | pot. solar thermal yield [MWh/a] |
|------------|---|---------------------------------|--------------------------|-----------------------|----------------------|---|----------------------------------|
| 1 | 1063.60 | 505.20 | 75.70 | 79.31 | 33.10 | 527.20 | 184.50 |
| 2 | 1049.30 | 1994.40 | 299.00 | 308.89 | 128.80 | 2440.60 | 900.60 |
| 3 | 1029.20 | 58.40 | 8.70 | 8.87 | 3.70 | 77.10 | 27.00 |
| 4 | 1061.10 | 125.00 | 18.70 | 19.58 | 8.10 | 126.30 | 44.20 |
| 5 | 954.10 | 179.50 | 26.90 | 25.28 | 10.50 | 116.60 | 40.80 |
| 6 | 1062.90 | 202.10 | 30.30 | 31.71 | 13.20 | 202.10 | 70.70 |
| 7 | 1041.40 | 179.90 | 26.90 | 27.65 | 11.40 | 413.70 | 144.60 |
| 8 | 1008.00 | 85.00 | 12.60 | 12.65 | 5.10 | 104.40 | 36.40 |
| 9 | 889.70 | 516.30 | 77.30 | 67.80 | 28.20 | 319.20 | 111.60 |
| 10 | 980.70 | 440.20 | 65.90 | 63.72 | 26.30 | 449.60 | 157.10 |
| 11 | 1063.00 | 978.50 | 146.70 | 153.53 | 64.10 | 1003.30 | 351.10 |
| 12 | 1012.90 | 1540.60 | 230.90 | 230.33 | 96.00 | 1850.90 | 647.70 |
| 13 | 979.30 | 662.80 | 98.90 | 95.80 | 39.40 | 751.30 | 262.40 |
| 14 | 946.00 | 3539.90 | 530.40 | 494.27 | 206.00 | 2819.80 | 986.40 |
| 15 | 1062.10 | 333.10 | 49.70 | 52.22 | 21.50 | 347.60 | 121.30 |
| 16 | 1057.90 | 629.60 | 94.20 | 98.31 | 40.90 | 746.30 | 260.80 |
| 17 | 1065.60 | 217.40 | 32.60 | 34.19 | 14.20 | 281.40 | 98.40 |
| 18 | 935.50 | 493.20 | 73.90 | 68.10 | 28.40 | 548.70 | 192.00 |
| 19 | 1050.80 | 44.70 | 6.70 | 6.93 | 2.90 | 44.70 | 15.60 |
| 20 | 1064.20 | 140.50 | 21.00 | 22.07 | 9.20 | 144.40 | 50.50 |
| 21 | 0.00 | 0.00 | 0.00 | 0.00 | 0.00 | 6.40 | 2.20 |
| 22 | 1061.60 | 213.10 | 31.90 | 33.39 | 13.90 | 222.00 | 77.70 |
| 23 | 1055.60 | 2135.80 | 320.20 | 332.77 | 139.00 | 2257.70 | 790.10 |
| 24 | 858.00 | 280.60 | 42.00 | 35.54 | 14.70 | 155.90 | 54.40 |
| 25 | 959.60 | 126.90 | 18.90 | 17.97 | 7.30 | 119.20 | 41.70 |
| 26 | 995.20 | 136.40 | 20.40 | 20.04 | 8.30 | 168.10 | 58.70 |
| 27 | 867.00 | 111.40 | 16.60 | 14.26 | 5.90 | 58.30 | 20.40 |
| 28 | 857.40 | 131.30 | 19.60 | 16.62 | 6.90 | 66.60 | 23.30 |
| 29 | 869.50 | 170.60 | 25.50 | 21.89 | 9.10 | 101.80 | 35.60 |
| 30 | 850.40 | 111.70 | 16.70 | 14.02 | 5.70 | 60.40 | 21.10 |
| 31 | 999.90 | 57.00 | 8.50 | 8.41 | 3.50 | 64.20 | 22.40 |
| 32 | 1002.90 | 59.10 | 8.80 | 8.75 | 3.60 | 66.80 | 23.40 |
| 33 | 881.70 | 385.20 | 57.60 | 50.13 | 20.70 | 261.90 | 91.50 |
| 34 | 918.40 | 122.70 | 18.40 | 16.63 | 6.90 | 128.50 | 44.90 |
| 35 | 906.50 | 531.30 | 79.50 | 71.09 | 29.60 | 606.30 | 211.90 |
| 36 | 1054.90 | 170.00 | 25.40 | 26.47 | 11.00 | 175.60 | 61.30 |
| 37 | 860.90 | 430.50 | 64.50 | 54.70 | 22.70 | 216.70 | 75.70 |
| 38 | 868.00 | 217.00 | 32.50 | 27.80 | 11.50 | 132.60 | 46.30 |
| 39 | 864.60 | 310.50 | 46.40 | 39.62 | 16.40 | 164.80 | 57.70 |
| 40 | 851.90 | 106.80 | 15.90 | 13.43 | 5.50 | 59.80 | 20.90 |
| 41 | 859.20 | 116.60 | 17.40 | 14.79 | 6.10 | 66.10 | 23.10 |
| 42 | 857.20 | 127.00 | 18.90 | 16.07 | 6.60 | 68.10 | 23.70 |
| 43 | 862.50 | 120.60 | 18.00 | 15.35 | 6.20 | 78.50 | 27.40 |
| 44 | 804.60 | 71.00 | 10.60 | 8.43 | 3.50 | 104.80 | 36.70 |
| 45 | 1022.40 | 47.00 | 7.00 | 7.09 | 2.90 | 50.20 | 17.50 |
| 46 | 1026.20 | 50.90 | 7.60 | 7.71 | 3.20 | 58.00 | 20.30 |
| 47 | 1030.20 | 37.50 | 5.60 | 5.70 | 2.30 | 43.70 | 15.30 |
| 48 | 1030.50 | 33.10 | 4.90 | 5.03 | 2.10 | 34.80 | 12.80 |
| 49 | 1026.90 | 46.20 | 6.90 | 7.00 | 2.90 | 49.70 | 17.40 |
| 50 | 1029.80 | 56.10 | 8.40 | 8.53 | 3.50 | 58.90 | 20.60 |
| 51 | 1022.10 | 56.70 | 8.50 | 8.55 | 3.50 | 60.20 | 21.10 |
| 52 | 864.00 | 124.00 | 18.60 | 15.81 | 6.60 | 102.20 | 35.70 |
| 53 | 959.00 | 23.80 | 3.50 | 3.37 | 1.40 | 66.80 | 23.40 |
| 54 | 1038.40 | 61.80 | 9.20 | 9.47 | 3.90 | 63.00 | 21.90 |
| 55 | 1018.80 | 18.90 | 2.80 | 2.84 | 1.10 | 32.70 | 11.40 |



| | | | | | | | |
|-----|---------|---------|--------|--------|--------|---------|---------|
| 56 | 1045.80 | 381.40 | 57.10 | 58.87 | 24.50 | 540.50 | 189.00 |
| 57 | 1055.60 | 78.60 | 11.70 | 12.25 | 5.00 | 85.30 | 29.80 |
| 58 | 1051.40 | 133.60 | 20.00 | 20.73 | 8.60 | 159.60 | 55.80 |
| 59 | 1053.20 | 371.00 | 55.50 | 57.67 | 23.90 | 542.40 | 189.50 |
| 60 | 1046.20 | 814.00 | 122.00 | 125.70 | 52.40 | 984.00 | 356.00 |
| 61 | 1058.20 | 2316.60 | 347.30 | 361.83 | 151.10 | 2339.10 | 816.60 |
| 62 | 1059.90 | 4193.50 | 628.80 | 656.04 | 273.90 | 4609.60 | 1612.90 |
| 63 | 1052.70 | 869.40 | 130.00 | 135.09 | 56.20 | 993.90 | 347.70 |
| 64 | 985.40 | 2345.80 | 351.10 | 341.18 | 141.50 | 2268.10 | 793.10 |
| 65 | 933.80 | 721.90 | 108.00 | 99.50 | 41.30 | 846.50 | 296.00 |
| 66 | 1058.90 | 126.20 | 18.90 | 19.72 | 8.20 | 128.00 | 44.80 |
| 67 | 1064.00 | 1297.30 | 194.60 | 203.74 | 85.10 | 1330.20 | 465.50 |
| 68 | 1059.80 | 543.50 | 81.40 | 85.02 | 35.40 | 547.50 | 191.60 |
| 69 | 1051.40 | 167.00 | 24.90 | 25.92 | 10.70 | 186.80 | 65.40 |
| 70 | 998.80 | 393.70 | 59.00 | 58.04 | 24.10 | 399.60 | 139.70 |
| 71 | 931.00 | 1266.90 | 189.80 | 174.09 | 72.50 | 1264.90 | 442.70 |
| 72 | 1058.70 | 800.90 | 120.00 | 125.15 | 52.10 | 836.60 | 292.60 |
| 73 | 850.80 | 106.30 | 15.90 | 13.35 | 5.50 | 115.90 | 40.50 |
| 74 | 929.80 | 115.60 | 17.00 | 15.86 | 6.30 | 65.50 | 22.80 |
| 75 | 1024.60 | 30.90 | 4.60 | 4.67 | 1.90 | 53.40 | 18.60 |
| 76 | 1061.30 | 99.30 | 14.80 | 15.56 | 6.50 | 100.70 | 35.20 |
| 77 | 896.70 | 510.20 | 76.40 | 67.53 | 28.10 | 295.60 | 103.40 |
| 78 | 1047.50 | 296.70 | 44.50 | 45.87 | 19.10 | 343.00 | 120.00 |
| 79 | 1064.60 | 38.00 | 5.60 | 5.97 | 2.40 | 38.00 | 13.30 |
| 80 | 1061.40 | 234.60 | 35.00 | 36.75 | 15.10 | 361.50 | 126.30 |
| 81 | 982.30 | 1132.00 | 169.70 | 164.13 | 68.40 | 888.90 | 310.80 |
| 82 | 966.20 | 75.30 | 11.20 | 10.74 | 4.40 | 145.10 | 50.60 |
| 83 | 1049.90 | 1494.40 | 223.70 | 231.58 | 96.40 | 1535.50 | 539.20 |
| 84 | 945.00 | 836.10 | 125.20 | 116.62 | 48.60 | 850.70 | 297.60 |
| 85 | 1040.30 | 126.80 | 18.90 | 19.47 | 7.90 | 208.60 | 72.70 |
| 86 | 922.40 | 900.20 | 134.80 | 122.56 | 51.10 | 509.80 | 178.40 |
| 87 | 1028.20 | 69.20 | 10.30 | 10.50 | 4.20 | 115.40 | 40.20 |
| 88 | 1064.40 | 592.70 | 88.80 | 93.12 | 38.70 | 604.40 | 211.40 |
| 89 | 1049.60 | 432.80 | 64.80 | 67.05 | 28.00 | 554.50 | 194.00 |
| 90 | 1064.30 | 453.00 | 67.90 | 71.16 | 29.70 | 458.40 | 160.40 |
| 91 | 1055.20 | 223.10 | 33.40 | 34.75 | 14.50 | 225.10 | 78.70 |
| 92 | 1060.30 | 627.70 | 94.00 | 98.24 | 41.00 | 690.50 | 241.60 |
| 93 | 931.50 | 1958.70 | 293.30 | 269.30 | 112.00 | 1200.30 | 419.50 |
| 94 | 948.50 | 1544.80 | 231.60 | 216.27 | 90.20 | 1543.40 | 540.10 |
| 95 | 974.20 | 334.10 | 50.00 | 48.04 | 19.90 | 394.90 | 138.10 |
| 96 | 957.90 | 638.40 | 95.60 | 90.26 | 37.50 | 645.40 | 225.70 |
| 97 | 979.10 | 364.10 | 54.40 | 52.62 | 21.70 | 386.70 | 135.10 |
| 98 | 1066.00 | 115.00 | 17.20 | 18.09 | 7.50 | 115.00 | 40.20 |
| 99 | 976.90 | 372.50 | 55.70 | 53.71 | 22.30 | 464.00 | 162.30 |
| 100 | 1062.20 | 161.00 | 24.10 | 25.24 | 10.50 | 179.00 | 62.60 |
| 101 | 1057.00 | 61.10 | 9.10 | 9.53 | 3.90 | 65.00 | 22.70 |
| 102 | 863.20 | 44.60 | 6.60 | 5.68 | 2.30 | 29.80 | 10.40 |
| 103 | 896.40 | 56.20 | 8.40 | 7.44 | 3.10 | 58.60 | 20.40 |
| 104 | 1061.30 | 264.00 | 39.50 | 41.36 | 17.20 | 277.10 | 96.90 |
| 105 | 896.40 | 54.80 | 8.20 | 7.25 | 3.00 | 72.40 | 25.30 |
| 106 | 914.30 | 227.70 | 34.10 | 30.73 | 12.70 | 226.50 | 79.30 |
| 107 | 932.70 | 894.80 | 134.20 | 123.18 | 51.40 | 443.30 | 155.10 |
| 108 | 898.80 | 34.20 | 5.10 | 4.54 | 1.80 | 38.00 | 13.20 |
| 109 | 1043.70 | 444.90 | 66.60 | 68.54 | 28.50 | 515.50 | 180.30 |
| 110 | 1063.00 | 191.30 | 28.60 | 30.01 | 12.40 | 198.20 | 69.30 |
| 111 | 941.10 | 586.70 | 87.90 | 81.50 | 33.90 | 584.80 | 204.50 |
| 112 | 1058.20 | 16.70 | 2.50 | 2.61 | 1.00 | 64.80 | 22.30 |
| 113 | 863.60 | 378.30 | 56.60 | 48.22 | 19.90 | 202.80 | 70.80 |
| 114 | 970.80 | 71.30 | 10.60 | 10.22 | 4.10 | 56.50 | 19.70 |
| 115 | 1054.00 | 77.00 | 11.50 | 11.98 | 5.00 | 79.40 | 27.80 |
| 116 | 933.20 | 221.00 | 33.00 | 30.44 | 12.40 | 155.50 | 54.20 |
| 117 | 914.00 | 320.90 | 48.10 | 43.29 | 18.00 | 134.50 | 47.00 |
| 118 | 874.30 | 181.30 | 27.10 | 23.40 | 9.70 | 95.20 | 33.30 |
| 119 | 1043.70 | 144.00 | 21.60 | 22.18 | 9.20 | 150.40 | 52.60 |
| 120 | 1042.80 | 51.50 | 7.70 | 7.93 | 3.30 | 51.50 | 18.00 |



| | | | | | | | |
|------------|-------------|-----------------|----------------|----------------|----------------|-----------------|-----------------|
| 121 | 925.00 | 191.10 | 28.60 | 26.09 | 10.80 | 196.60 | 68.60 |
| 122 | 903.80 | 190.80 | 28.50 | 25.45 | 10.50 | 172.50 | 60.30 |
| 123 | 1053.60 | 871.00 | 130.50 | 135.45 | 56.30 | 916.80 | 320.60 |
| 124 | 956.90 | 62.50 | 9.20 | 8.83 | 3.60 | 60.20 | 21.00 |
| 125 | 930.40 | 323.20 | 48.40 | 44.38 | 18.50 | 260.70 | 91.10 |
| 126 | 1044.90 | 46.80 | 7.00 | 7.22 | 3.00 | 82.40 | 28.70 |
| 127 | 997.30 | 222.00 | 33.10 | 32.68 | 13.40 | 264.80 | 92.50 |
| 128 | 919.40 | 218.10 | 32.60 | 29.60 | 12.10 | 223.70 | 78.20 |
| 129 | 1023.40 | 50.80 | 7.50 | 7.67 | 3.10 | 87.10 | 30.40 |
| 130 | 936.10 | 249.30 | 37.30 | 34.45 | 14.30 | 248.30 | 86.80 |
| 131 | 1059.10 | 121.50 | 18.00 | 18.99 | 7.70 | 122.30 | 42.80 |
| 132 | 945.90 | 259.70 | 38.90 | 36.26 | 14.90 | 267.90 | 93.60 |
| 133 | 953.50 | 697.40 | 104.50 | 98.15 | 40.90 | 714.50 | 250.00 |
| 134 | 1001.70 | 757.30 | 113.30 | 111.97 | 46.40 | 883.20 | 308.80 |
| 135 | 1065.50 | 115.20 | 17.20 | 18.12 | 7.50 | 118.20 | 41.30 |
| 136 | 1047.00 | 80.00 | 12.00 | 12.36 | 5.10 | 165.90 | 57.90 |
| 137 | 1061.50 | 59.60 | 8.90 | 9.34 | 3.90 | 62.20 | 21.70 |
| 138 | 879.10 | 170.20 | 25.30 | 22.08 | 9.10 | 127.20 | 44.40 |
| 139 | 1014.70 | 532.40 | 79.70 | 79.74 | 33.10 | 638.40 | 223.10 |
| 140 | 1057.00 | 59.90 | 8.90 | 9.35 | 3.80 | 68.50 | 23.80 |
| 141 | 1052.90 | 93.10 | 13.90 | 14.47 | 5.90 | 99.40 | 34.70 |
| 142 | 1066.40 | 158.60 | 23.80 | 24.96 | 10.40 | 158.80 | 55.50 |
| 143 | 916.80 | 170.00 | 25.50 | 23.00 | 9.50 | 186.30 | 65.10 |
| 144 | 1049.50 | 167.60 | 25.00 | 25.96 | 10.60 | 208.50 | 72.70 |
| 145 | 1058.70 | 313.00 | 46.80 | 48.91 | 20.30 | 343.00 | 120.00 |
| 146 | 1066.70 | 96.90 | 14.50 | 15.26 | 6.30 | 96.90 | 33.90 |
| 147 | 1027.70 | 18.00 | 2.70 | 2.73 | 1.10 | 154.30 | 54.00 |
| 148 | 1061.30 | 170.50 | 25.50 | 26.71 | 11.10 | 173.70 | 60.80 |
| 149 | 1066.50 | 232.10 | 34.80 | 36.54 | 15.20 | 232.10 | 81.20 |
| 150 | 941.60 | 601.60 | 90.10 | 83.61 | 34.80 | 590.10 | 206.50 |
| 151 | 1065.30 | 139.40 | 20.80 | 21.92 | 9.00 | 146.50 | 51.10 |
| 152 | 1064.10 | 217.80 | 32.60 | 34.21 | 14.20 | 234.10 | 81.90 |
| 153 | 921.80 | 543.20 | 81.40 | 73.91 | 30.70 | 478.30 | 167.40 |
| 154 | 1055.30 | 160.40 | 24.00 | 24.98 | 10.30 | 163.60 | 57.20 |
| Sum | n.a. | 63052.50 | 9440.50 | 9275.40 | 3855.10 | 62945.10 | 22071.90 |

